

# MILLTURN TOOLING

---

■ TURNING TOOL SYSTEM CHART/SELECTION GUIDE TABLE .....	E1
■ 45° TYPE S (TILT TYPE) CARTRIDGE/ 90° TYPE F (RIGHT ANGLE TYPE) CARTRIDGE .....	E5
<b>BIG-PLUS BBT</b> .....	<b>E9</b>
■ FOR EXTERNAL TURNING .....	E11
■ FOR INTERNAL TURNING .....	E14
<b>HSK-T</b> .....	<b>E15</b>
■ FOR EXTERNAL TURNING .....	E17
■ FOR INTERNAL TURNING .....	E21
<b>BIG CAPTO</b> .....	<b>E25</b>
■ FOR EXTERNAL TURNING .....	E27
■ FOR INTERNAL TURNING .....	E33
■ COLLET CHUCK .....	E39
■ MILLING CHUCK .....	E46
■ HYDRAULIC CHUCK.....	E48
■ SHRINK CHUCK.....	E51
■ CK BORING SYSTEM .....	E52
■ TAPPER .....	E54
■ GENERAL TOOLHOLDER .....	E55
■ OTHER TOOLS .....	E59

# Revolutionary modular system for turning

## 45° (Tilt Type) S Type



Tilting the “B” axis 45° minimizes the cutting forces transmitted to the machine spindle.



E

MILLTURN TOOLING

## 90° (Right Angle Type) F Type



Basic holder can be used with both right- and left-hand cartridges.



### DOUBLE-CLAMPING SYSTEM

Double-clamping system that utilizes a “Push and Draw” mechanism to fix inserts securely

Secure insert clamping has been realized through the double-clamping system, which pushes the insert downwards while at the same time generating drawing force on the insert contact surface.

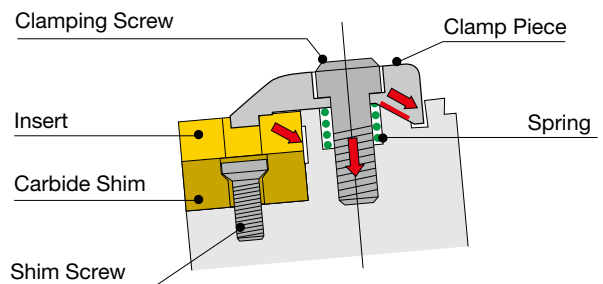

The issue of a valuable holder breakage caused by problems such as chipping has been eliminated through the use of a “modular system”, resulting in enhanced efficiency and economy.

**45° incline avoids interference with the chuck**

Tool length can be minimized.

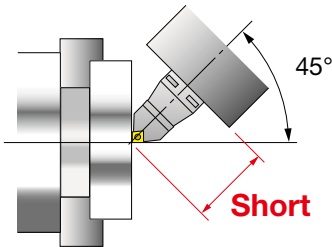

A total of 15 types of cartridges are available to support various applications



**Strong clamping system**

The two shallow-tapered clamping screws securely maintain contact between the cartridge and the basic holder flange face.

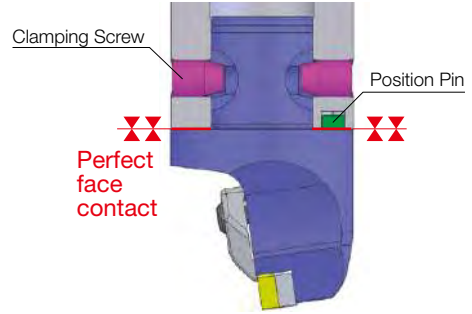

**Comprehensive interference countermeasures**

A series of “near-center” type cartridges are available, eliminating interference with the tailstock.

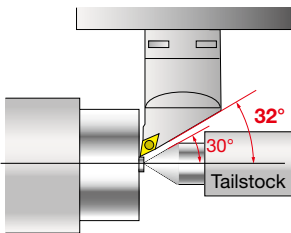

11 types of cartridges are available to support various applications

Both right hand and left hand are available.

**Strong clamping system**

In the F Type clamping system, cartridges are fixed using the two front clamping screws. The interlocking drive slot receives the cutting torque firmly.

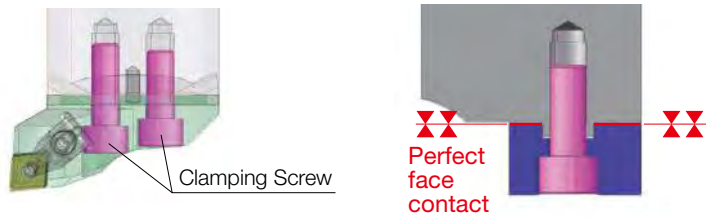

**Easy attachment and removal of inserts**

Insert attachment and removal can be performed easily by the built-in spring. Loosen the clamping screw one full rotation, lightly press the clamp piece with a finger, and its tip will pop up.

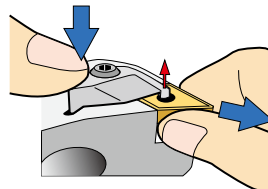

# Turning Tool

## ◆ Selection Guide Table

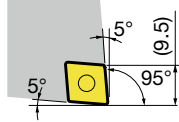
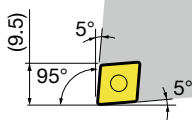
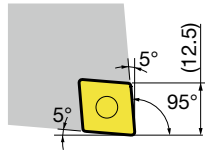
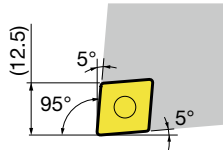
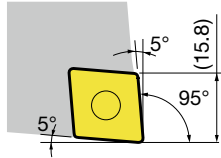
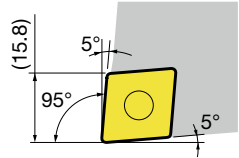
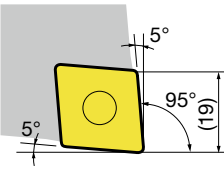
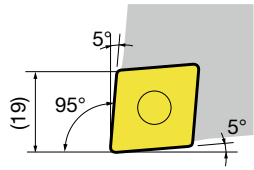
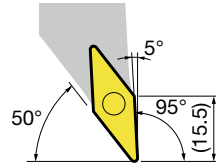
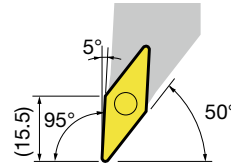
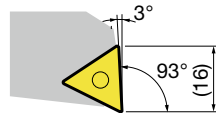
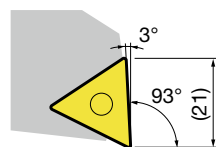
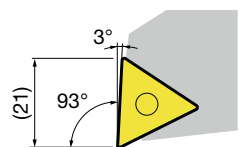
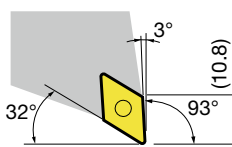
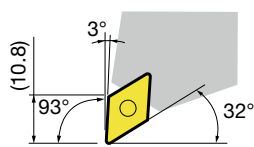
Entering angle	Insert	Cartridge or Mono-block		Right hand	Left hand
		S Type	F Type		
95°	CN0903 (CN0904)		No.19		
	CN1204	No.1	No.10-1		
	CN1606	No.8-1	No.10-2		
	CN1906	No.8-2			
	VB1604 VC1604	No.7			
	93°	TN1604	No.2-1	No.12	
TN2204		No.2-2			
DN1104			No.20		

TURNING TOOL

E

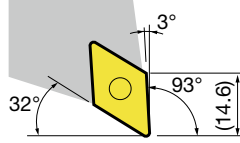
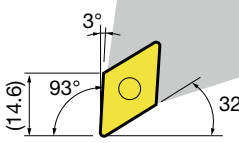
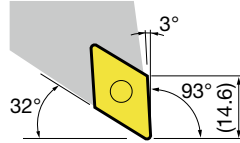
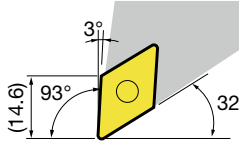
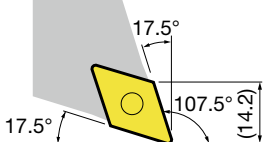
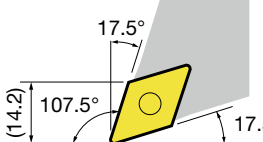
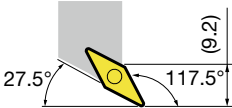
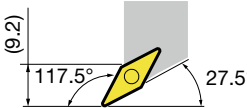
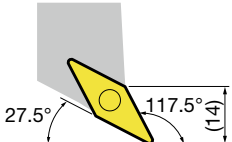
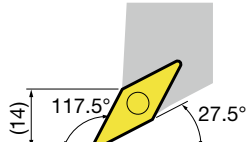
Entering angle	Insert	Cartridge or Mono-block		Right hand	Left hand
		S Type	F Type		
<b>93°</b>	DN1504 (DN1506)	<b>No.4</b>	<b>No.13</b>		
	DN1504 (DN1506)	<b>No.6</b>	<b>No.18</b>		
<b>107.5°</b>	DN1504 (DN1506)	<b>No.3</b>			
<b>117.5°</b>	VB1103 VC1103		<b>No.21</b>		
	VB1604 VC1604	<b>No.5</b>	<b>No.15</b>		

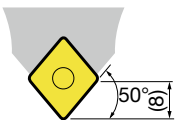
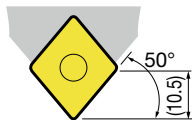
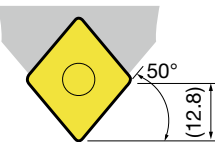
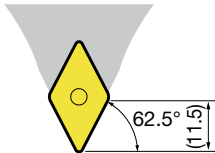
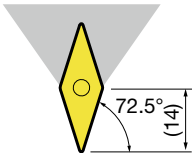
Neutral				
Insert				
CN12	CN16	CN19	DN1504 (DN1506)	VB1604 / VC1604
<b>No.1</b>	<b>No.8-1</b>	<b>No.8-2</b>	<b>No.3</b>	<b>No.5</b>
				

## Cartridge

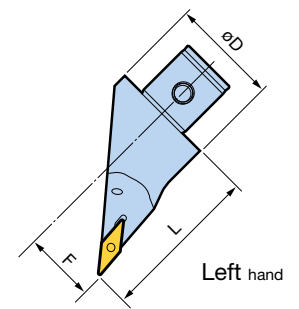
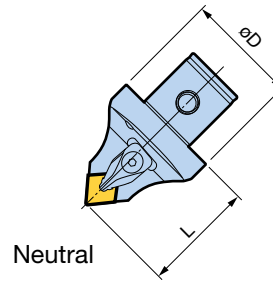

Type	Entering angle	No.	Hand	Model	Insert	L	F	øD	Clamp Piece	weight (kg)
S50	95°	No.1	N	S50-DCLNN-00050-12	CN1204 Rhombic 80°	50	0	50	CP2	0.47
	93°	No.2-1	R	-DTJNR-00050-16	TN1604 Triangle 60°	50	0	50	CP1	0.50
			L	-DTJNL-00050-16					CP2	
		No.2-2	R	-DTJNR-00050-22	TN2204 Triangle 60°				CP2	
			L	-DTJNL-00050-22						
	93°	No.4	R	-DDJNR-00050-15	DN1504 <sup>※1</sup> (DN1506) Rhombic 55°	50	0	50	CP2	0.47
			L	-DDJNL-00050-15		75	33			0.75
		No.6	R	-DDJNR-33075-15						50
			L	-DDJNL-33075-15						
	107.5°	No.3	N	-DDHNN-00050-15		VB1604 <sup>※2</sup> VC1604 Rhombic 35°	75	33	50	M3.5 <sup>※3</sup>
95°	No.7	R	-SVLBR-33075-16	50			0	0.44		
		L	-SVLBL-33075-16							
117.5°	No.5	N	-SVQBN-00050-16							
S63	95°	No.8-1	N	S63-DCLNN-00060-16	CN1606 Rhombic 80°	60	0	63	CP3	0.95
		No.8-2	N	-00060-19	CN1906 Rhombic 80°				CP5	0.92

1. Wrench is not included.  
2. Insert is not included.

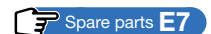

※1 A carbide shim for DN1504 (thickness: 4.76mm) is included. When using a DN1506 insert (thickness: 6.35mm), replace with the DNS1506 carbide shim (optional).

※2 Either VB1604 or VC1604 insert can be mounted. ※3 M3.5 is a screw-on type.

Right hand Left hand Neutral

### Cartridge Model Description

**S50 - D C L N N - 00 050 - 12**

- S50: Cartridge Type and Size
- D: Clamping Method (Double Clamp)
- C: Insert Shape (Rhombic 80°)
- L: Insert Shape (Triangle 60°)
- N: Insert Shape (Rhombic 55°)
- N: Insert Shape (Rhombic 35°)
- 00: Value F (Offset value)
- 050: L dimension
- 12: Insert size

Clamping Method		Insert Shape		Entering Angle		Relief Angle		Hand	
D	Double Clamp	C	Rhombic 80°	J	93°	N	0° negative	R	Right hand
S	Screw-on	T	Triangle 60°	L	95°	B	5° positive	L	Left hand
		D	Rhombic 55°	H	107.5°			N	Neutral
		V	Rhombic 35°	Q	117.5°				
				U	93°				

**90° TYPE F (Right Angle Type)**

## Cartridge

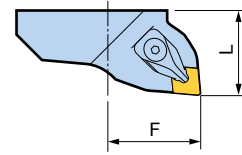

Right hand

**[F50 Type]**

Entering angle	No.	Hand	Model	Insert	F	L	Clamp Piece	weight (kg)
95°	No.10-1	R	F50-DCLNR-35035-12	CN1204 Rhombic 80°	35	35	CP2	0.25
		L	-DCLNL-35035-12					
	No.10-2	R	F50-DCLNR-35035-16	CN1606 Rhombic 80°	35	35	CP3	
		L	-DCLNL-35035-16					
93°	No.12	R	F50-DTJNR-35035-16	TN1604 Triangle 60°	35	35	CP1	
		L	-DTJNL-35035-16					
	No.13	R	F50-DDJNR-35035-15	DN1504 <sup>※1</sup> (DN1506) Rhombic 55°	35	35	CP2	0.22
		L	-DDJNL-35035-15					0.23
	No.18	R	F50-DDJNR-35050-15		35	50	CP2	0.30
		L	-DDJNL-35050-15					

1. Wrench is not included.

2. Insert is not included.

 Spare parts **E7**

※1 A carbide shim for DN1504 (thickness: 4.76mm) is included.

When using a DN1506 insert (thickness: 6.35mm), replace with the DNS1506 carbide shim (optional).

**[F63 Type]**

Entering angle	No.	Hand	Model	Insert	F	L	Clamp Piece	weight (kg)
95°	No.10-1	R	F63-DCLNR-45035-12	CN1204 Rhombic 80°	45	35	CP2	0.33
		L	-DCLNL-45035-12					
	No.10-2	R	F63-DCLNR-45035-16	CN1606 Rhombic 80°	45	35	CP3	
		L	-DCLNL-45035-16					
93°	No.12	R	F63-DTJNR-45035-16	TN1604 Triangle 60°	45	35	CP1	0.35
		L	-DTJNL-45035-16					0.33
	No.13	R	F63-DDJNR-45035-15	DN1504 <sup>※1</sup> (DN1506) Rhombic 55°	45	35	CP2	0.31
		L	-DDJNL-45035-15					
	No.18	R	F63-DDJNR-45055-15		45	55	CP2	0.41
		L	-DDJNL-45055-15					
117.5°	No.15	R	F63-SVQBR-45035-16	VB1604 <sup>※2</sup> VC1604 Rhombic 35°	45	35	M3.5 <sup>※3</sup>	0.26
		L	-SVQBL-45035-16					

1. Wrench is not included.

2. Insert is not included.

 Spare parts **E7**

※1 A carbide shim for DN1504 (thickness: 4.76mm) is included.

When using a DN1506 insert (thickness: 6.35mm), replace with the DNS1506 carbide shim (optional).

※2 Either VB1604 or VC1604 insert can be mounted.

※3 M3.5 is a screw-on type.

Right hand     Left hand

Double Clamp Type

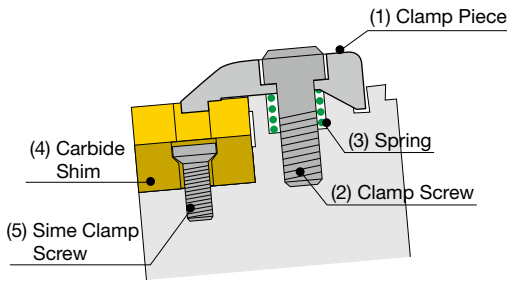

■ Clamp Piece Set

Set Model	(1) Clamp Piece	(2) Clamp Screw	(3) Spring	Compatible Insert
<b>SCP1</b>	CP1	M5 x 20	ø8 x 10	TN1604
<b>SCP2</b>	CP2			CN1204, TN2204 DN1504, DN1506
<b>SCP2S</b> ※ <b>NEW</b>			ø6.8x11.5	DN1504, DN1506
<b>SCP3</b>	CP3		ø8 x 10	CN1606
<b>SCP5</b>	CP5			CN1906
<b>SCP7</b>	CP7			CN0903, CN0904 DN1104

- 1 pce. each of the clamp piece, clamp screw and spring are included in the set.
- The tightening wrench is a 4mm hex wrench. T-type hex wrench is sold as Model T-4.
- ※Set Model: SCP2S is exclusive for C4-DDHNN-00075-15.

■ Carbide Shim Set

Compatible Insert	Set Model	(4) Carbide Shim	(5) Sime Clamp Screw	Torx, Torx Plus Size
CN0903	<b>SCNS0903C</b>	CNS0903C	M3x 7	10IP
CN0904	<b>SCNS0904C</b>	CNS0904C	M3x 7	10IP
CN1204	<b>SCNS1204</b>	CNS1204	M4x 8	T15
CN1606	<b>SCNS1606</b>	CNS1606	M5x12	T20
CN1906	<b>SCNS1906</b>	CNS1906	M5x12	T20
TN1604	<b>STNS1604</b>	TNS1604	M3x 7	T10
TN2204	<b>STNS2204</b>	TNS2204	M4x 8	T15
DN1104	<b>SDNS1104C</b>	DNS1104C	M3x 7	10IP
DN1504	<b>SDNS1504</b>	DNS1504	M4x 8	T15
DN1506	<b>SDNS1506</b>	DNS1506	M4x 8	T15

- The set contains one each of a carbide sheet and one screw.
- The type of tightening wrench varies depending on the set. T○ includes a Torx wrench, ○IP includes a Torx plus wrench.

E  
S/F SPARE PARTS



Insert Clamp Screw for  
**VB11, VC11, VB16 and VC16 Inserts**

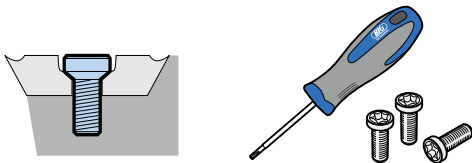

Compatible Insert	Set Model	Screw	Wrench Model
VB1103 VC1103	<b>S2.5S-7IP</b>	M2.5x6.5	FS-7IP
VB1604 VC1604	<b>S3508DS</b>	M3.5x8	DA-T15

• The set contains 1 wrench and 10 screws.

For Type S Basic Holder  
**Clamping Screw Set**

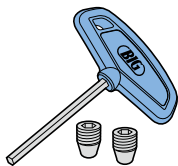

Type	Set Model	Screw (2 pcs)	T-type Wrench (1 pc)
S50	<b>CK5S</b>	M10 x P1.0	CK-T5
S63	<b>CK6S</b>	M12 x P1.0	CK-T6

# Turning Tool System Chart

(Note) Contact us, as interference may occur depending on the machine model.

## 45°

### S Type Basic Holder E11

	L
BBT40M-S50- 75	75
BBT50M-S50-120	120

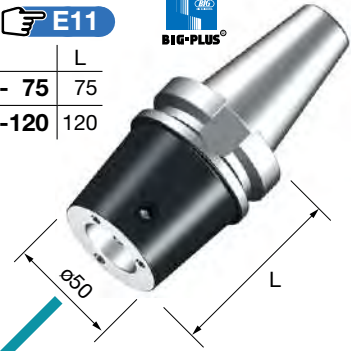

### S Type (Tilt Type) Cartridge E5

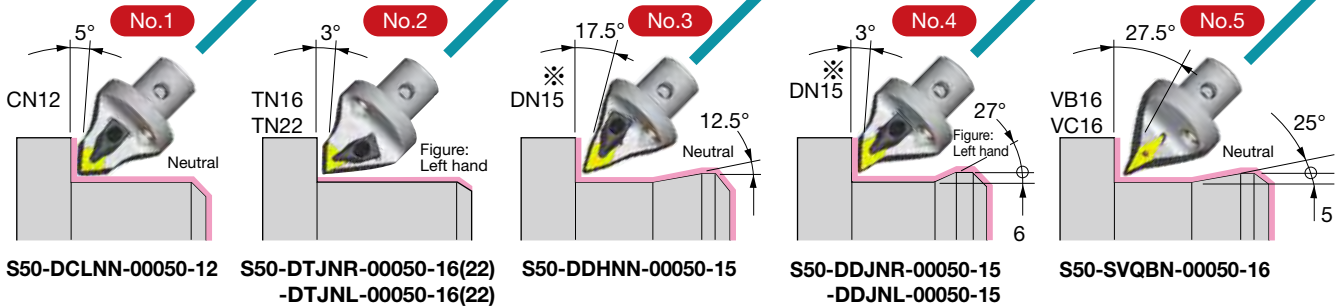
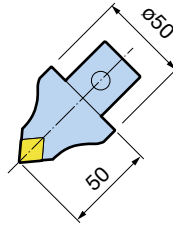

S50-DCLNN-00050-12    S50-DTJNR-00050-16(22) -DTJNL-00050-16(22)    S50-DDHNN-00050-15    S50-DDJNR-00050-15 -DDJNL-00050-15    S50-SVQBN-00050-16

※When using a DN1506 insert (thickness: 6.35mm), replace the standard carbide shim with the DNS1506 (optional).

E

TURNING TOOL SYSTEM CHART

## 90°

### F Type Basic Holder E12

	L	øD
BBT40M-F50- 75	75	50
-105	105	50
BBT50M-F63- 70	70	63
-130	130	63



### S Type Basic Holder E11

### S Type Cartridge E5



- No.1
- No.3
- No.5
- No.8

### F Type (Right Angle Type) Cartridge E6

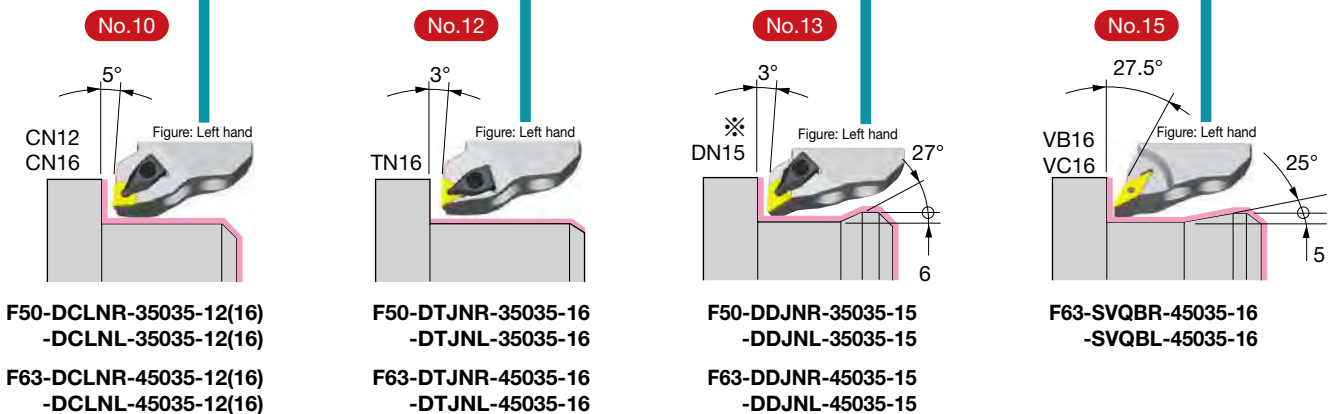
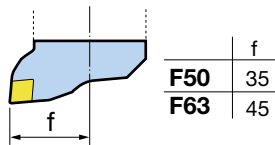

F50-DCLNR-35035-12(16) -DCLNL-35035-12(16)    F50-DTJNR-35035-16 -DTJNL-35035-16    F50-DDJNR-35035-15 -DDJNL-35035-15    F63-SVQBR-45035-16 -SVQBL-45035-16  
F63-DCLNR-45035-12(16) -DCLNL-45035-12(16)    F63-DTJNR-45035-16 -DTJNL-45035-16    F63-DDJNR-45035-15 -DDJNL-45035-15

※When using a DN1506 insert (thickness: 6.35mm), replace the standard carbide shim with the DNS1506 (optional).

# Turning Tool System Chart

DUAL CONTACT  
**BBT**  
SHANK

## S Type Basic Holder E11

	L
BBT50M-S63-110	110

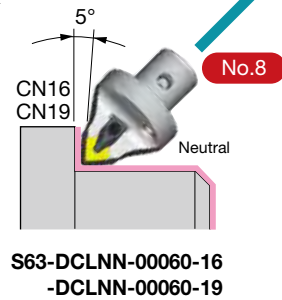
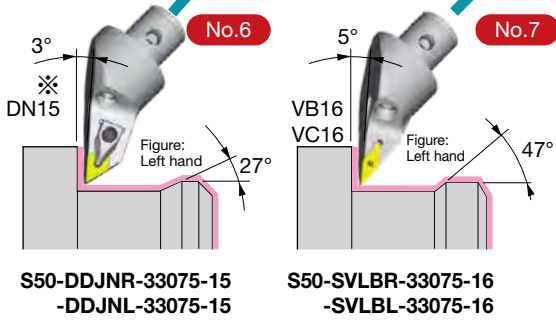
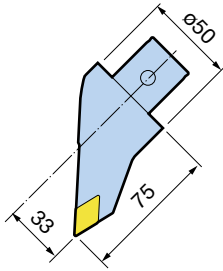
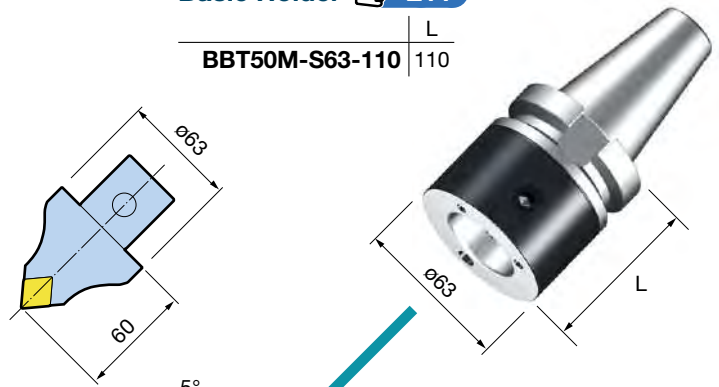

S50-DDJNR-33075-15  
-DDJNL-33075-15

S50-SVLBR-33075-16  
-SVLBL-33075-16

S63-DCLNN-00060-16  
-DCLNN-00060-19

Internal boring bar  
Internal threading tool



Side Lock Holder  
for Boring Bar

 E14

Square tool



Square Tool Holder

 E13

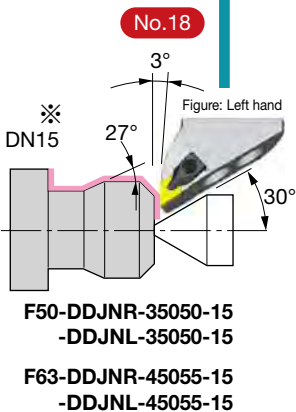

F50-DDJNR-35050-15  
-DDJNL-35050-15

F63-DDJNR-45055-15  
-DDJNL-45055-15

E  
TURNING TOOL SYSTEM CHART

Basic Holder

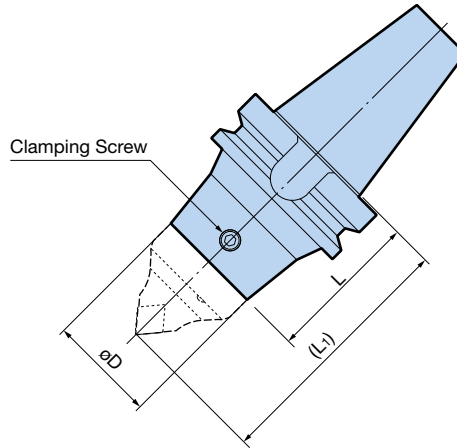

BIG-PLUS (BBT Shank) tools can be used on both BIG-PLUS spindles and conventional **BT spindles**.

Type	Model	øD	L	(L <sub>1</sub> )	Clamping Screw	Weight (kg)
S50	<b>BBT40M-S50- 75</b>	50	75	125	CK5S	1.7
S50	<b>BBT50M-S50-120</b>	50	120	170	CK5S	5.4
S63	<b>-S63-110</b>	63	110	170	CK6S	5.4

1. Clamping screw is included with the basic holder.

Spare parts **E7**

Cartridges **E5**

E  
45° TYPE S HOLDER

Basic Holder

Center through

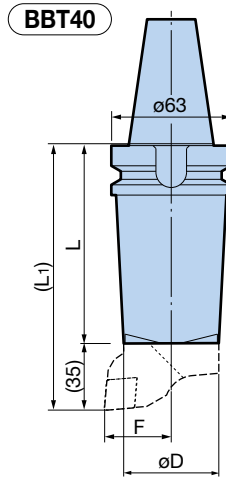

Fig. 1

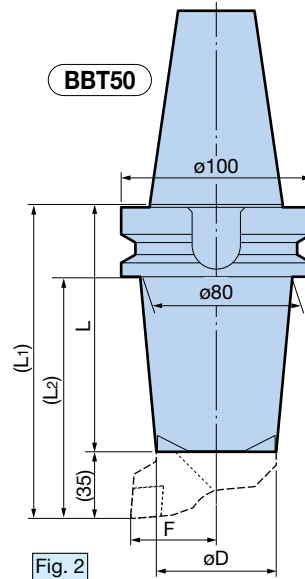

Fig. 2

Above figure shows a left-handed cartridge mounted.

BIG-PLUS (BBT Shank) tools can be used on both BIG-PLUS spindles and conventional **BT** spindles.

Type	Model	Fig.	$\phi D$	L	(L <sub>1</sub> )	(L <sub>2</sub> )	F	Weight (kg)
F50	<b>BBT40M-F50- 75</b>	1	50	75	110	—	35	1.7
	<b>-105</b>			105	140	—		2.3
F63	<b>BBT50M-F63- 70</b>	2	63	70	105	67	45	4.5
	<b>-130</b>			130	165	127		6.4

- Both M10×22L and M10×25L bolts to clamp a Cartridge are included with the basic holder.
- Hex wrench is not included.
- The nozzle holes contain internal threads.  
Plugging one allows for ejection from the other nozzle only.

Spare parts **E7**

Cartridges **E6**

# SQUARE TOOL HOLDER

## [180° Type]



BIG-PLUS (BBT Shank) tools can be used on both BIG-PLUS spindles and conventional **BT spindles**.

Hand	Model	□ B	L	L <sub>1</sub>	A	øD	Weight (kg)
R	<b>BBT40M-180-BH20R-110</b>	20	110	70	27	80	2.8
L	<b>-BH20L-110</b>						
R	<b>-180-BH25R-130</b>	25	130	90	31.5	90	3.4
L	<b>-BH25L-130</b>						
R	<b>BBT50M-180-BH25R-140</b>	25	140	90	50	120	7.6
L	<b>-BH25L-140</b>						

Right hand  Left hand

Center through

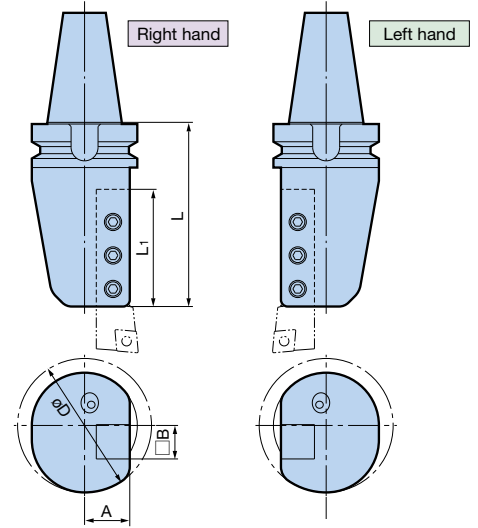

## [180° Multi Type]

- Mounting 3 tools minimizes ATC time.



BIG-PLUS (BBT Shank) tools can be used on both BIG-PLUS spindles and conventional **BT spindles**.

Hand	Model	□ B	L	L <sub>1</sub>	A	øD	Weight (kg)
R	<b>BBT40M-180-3BH20R-110</b>	20	110	70	35	90	3.4
L	<b>-3BH20L-110</b>						
R	<b>BBT50M-180-3BH25R-140</b>	25	140	90	50	120	9.5
L	<b>-3BH25L-140</b>						

Right hand  Left hand

Center through

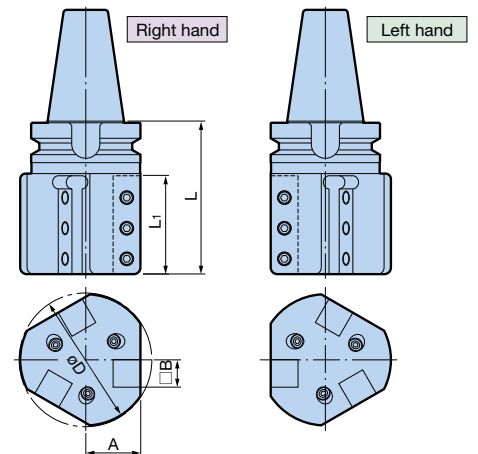

### Caution

• 60° indexing capability is required for the machine spindle.

Clamping diameter:  $\varnothing 8 - \varnothing 50$

# Side Lock Holder for Boring Bar

DUAL CONTACT  
**BBT**  
SHANK

Holder for internal boring and threading.

Center through

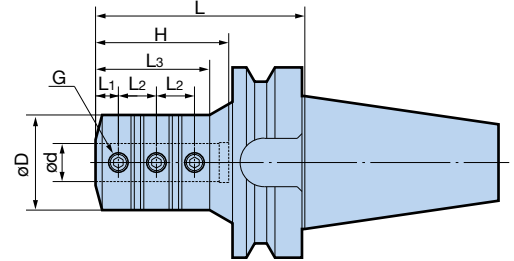

BIG-PLUS (BBT Shank) tools can be used on both BIG-PLUS spindles and conventional BT spindles.

Model	$\varnothing d$	$\varnothing D$	L	L <sub>1</sub>	L <sub>2</sub>	L <sub>3</sub>	H	Clamp Screw G	Plug A	Plug B	Weight (kg)
<b>BBT40M-BSL 8- 75</b>	8	25	75	6	10	40	40	M 6 P1.0	M6 x 5L	M4 x 4L	1.2
<b>-BSL10- 80</b>	10	29	80	8	12	45	50	M 8 P1.0	M6 x 5L	M5 x 5L	1.3
<b>-BSL12- 90</b>	12	34	90	8	16	53	55	M 8 P1.0	M6 x 5L	M6 x 5L	1.4
<b>-BSL16-100</b>	16	40	100	10	21	65	68	M10 P1.25	M6 x 5L	M6 x 5L	1.6
<b>-BSL20-100</b>	20	50	100	12	20	67	70	M10 P1.25	M6 x 5L	M6 x 5L	1.9
<b>-BSL25-110</b>	25	55	110	14	23	83	74	M12 P1.5	M8 x 8L	M6 x 5L	2.2
<b>-BSL32-125</b>	32	64	125	16	26	—	83	M12 P1.5	M8 x 8L	M6 x 5L	2.8
<b>-BSL40-150</b>	40	80	150	18	32	—	98	M16 P1.5	M10 x 10L	M6 x 5L	4.5
<b>BBT50M-BSL16-105</b>	16	40	105	10	21	61	68	M10 P1.25	M6 x 5L	M6 x 5L	4.1
<b>-BSL20-110</b>	20	50	110	12	20	60	70	M10 P1.25	M6 x 5L	M6 x 5L	4.5
<b>-BSL25-120</b>	25	55	120	14	23	70	74	M12 P1.5	M8 x 8L	M6 x 5L	4.8
<b>-BSL32-125</b>	32	64	125	16	26	80	83	M12 P1.5	M8 x 8L	M6 x 5L	5.2
<b>-BSL40-135</b>	40	80	135	18	32	91	98	M16 P1.5	M10 x 10L	M6 x 5L	6.4
<b>-BSL50-145</b>	50	90	145	18	36	102	115	M16 P1.5	M10 x 10L	M6 x 5L	7.1

- Switchable coolant flow between side through and center through with plug screws.

Adjustable for right or left hand operation.

※ Plugs AB are included.

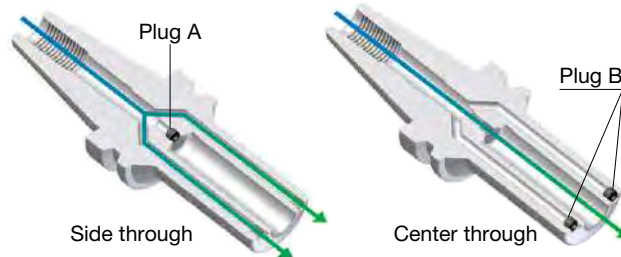

For BSL SIDE LOCK HOLDE

## BSL Sleeve

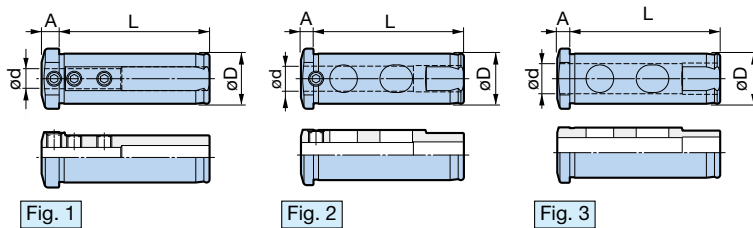

Model	Fig.	$\varnothing d$	$\varnothing D$	L	A
<b>BSLA20- 6</b>		6	20	60	5
<b>- 8</b>	1	8			7
<b>-10</b>	2	10			5
<b>-12</b>	3	12		5	
<b>-16</b>		16	5		
<b>BSLA32-10</b>	1	10	32	75	9
<b>-12</b>		12			9
<b>-16</b>	2	16			6
<b>-20</b>	3	20		6	
<b>-25</b> <small>NEW</small>		25	6		
<b>BSLA40-16</b>	1	16	40	94	6
<b>-20</b>		20			
<b>-25</b>	3	25			
<b>-32</b>		32			

# Turning Tool System Chart

(Note) Contact us, as interference may occur depending on the machine model.

## 45°

### S Type Basic Holder

HSK-T 50-S50-	60	L
-T 63-S50-	60	60
- 75	75	75
-100	100	100
-T100-S50-	115	115

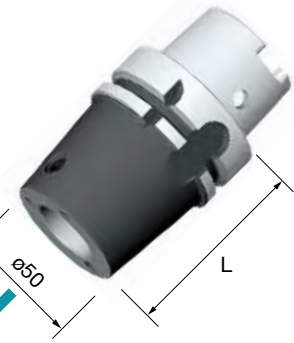

### S Type (Tilt Type) Cartridge

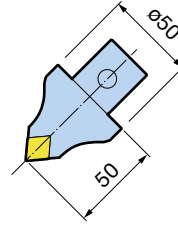

<p><b>No.1</b></p> <p>S50-DCLNN-00050-12</p>	<p><b>No.2</b></p> <p>S50-DTJNR-00050-16(22) -DTJNL-00050-16(22)</p>	<p><b>No.3</b></p> <p>S50-DDHNN-00050-15</p>	<p><b>No.4</b></p> <p>S50-DDJNR-00050-15 -DDJNL-00050-15</p>	<p><b>No.5</b></p> <p>S50-SVQBN-00050-16</p>
--	--	--	--	--

※When using a DN1506 insert (thickness: 6.35mm), replace the standard carbide shim with the DNS1506 (optional).

TURNING TOOL SYSTEM CHART

**E**

### F Type Basic Holder

HSK-T 63-F63-	50	L
- 75	75	75
-100	100	100
-130	130	130
-170	170	170
-T100-F63-	100	100
-150	150	150



### S Type Basic Holder

### S Type Cartridge



### F Type (Right Angle Type) Cartridge

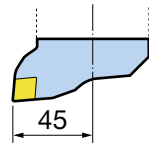

<p><b>No.10</b></p> <p>F63-DCLNR-45035-12(16) -DCLNL-45035-12(16)</p>	<p><b>No.12</b></p> <p>F63-DTJNR-45035-16 -DTJNL-45035-16</p>	<p><b>No.13</b></p> <p>F63-DDJNR-45035-15 -DDJNL-45035-15</p>	<p><b>No.15</b></p> <p>F63-SVQBR-45035-16 -SVQBL-45035-16</p>
---	---	---	---

※When using a DN1506 insert (thickness: 6.35mm), replace the standard carbide shim with the DNS1506 (optional).



# Turning Tool System Chart

DUAL CONTACT  
**HSK-T**  
SHANK

## S Type Basic Holder E17

	L
HSK-T 63-S63- 70	70
- 90	90
-T100-S63-105	105

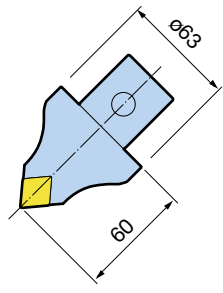
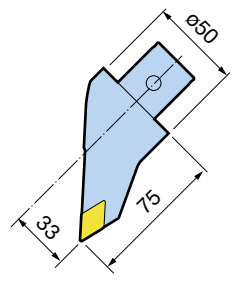

**No.6**

3°  
DN15  
Figure: Left hand  
27°

S50-DDJNR-33075-15  
-DDJNL-33075-15

**No.7**

5°  
VB16  
VC16  
Figure: Left hand  
47°

S50-SVLBR-33075-16  
-SVLBL-33075-16

**No.8**

5°  
CN16  
CN19  
Neutral

S63-DCLNN-00060-16  
-DCLNN-00060-19

Internal boring bar  
Internal threading tool

**Side Lock Holder for Boring Bar**  
 E21

Square tool

**Square Tool Holder**  
 E19

**No.18**

3°  
DN15  
Figure: Left hand  
27°  
30°

F63-DDJNR-45055-15  
-DDJNL-45055-15

**SMART DAMPER Turning Adapter**  
 E22

E  
TURNING TOOL SYSTEM CHART

Center through

Basic Holder

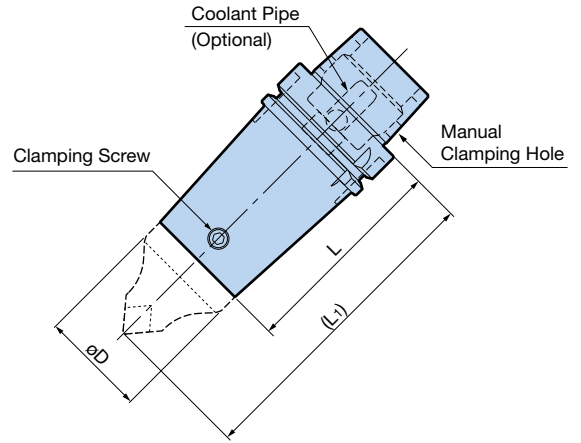

Type	Model	øD	L	(L-1)	Clamping Screw	Weight (kg)
S50	<b>HSK-T50-S50- 60</b>	50	60	110	CK5S	0.8
S50	<b>HSK-T63-S50- 60</b>	50	60	110	CK5S	1.1
	<b>- 75</b>		75	125		1.4
	<b>-100</b>		100	150		1.8
S63	<b>-S63- 70</b>	63	70	130	CK6S	1.4
	<b>- 90</b>		90	150		1.9
S50	<b>HSK-T100-S50-115</b>	50	115	165	CK5S	3.7
S63	<b>-S63-105</b>	63	105	165	CK6S	4.0

1. Clamping screw is included with the basic holder.
2. Coolant pipe is not included.

Spare parts **E7**  
 Cartridges **E5**

45° TYPE S HOLDER

Coolant Pipe

**Caution**  
For machines capable of supplying coolant through the spindle, the Coolant Pipe should be fitted to all the holders to protect against accidental selection of coolant.

[Mono Block Type]

- Some machine tool builders may recommend the Mono Block Type. Check with the machine when selecting Mono Block or 1° Swing Type.

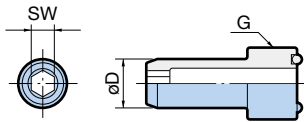

Model	øD	G	Hexagon SW	
<b>HSK 50-CP</b>	10	M16 x P1	5	
<b>HSK 63-CP</b>	12	M18 x P1	6	
<b>HSK100-CP</b>	16	M24 x P1.5	8	

[1° Swing Type]

- The DIN standards require movement range of ±1°. An exclusive wrench (optional) is required when attaching the 1° Swing Type.

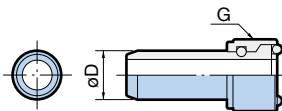

Model	øD	G	Wrench Model (Optional)	
<b>HSK 50-CPM</b>	10	M16 x P1	CPW- 50	
<b>HSK 63-CPM</b>	12	M18 x P1	CPW- 63	
<b>HSK100-CPM</b>	16	M24 x P1.5	CPW-100	

Center through

Basic Holder

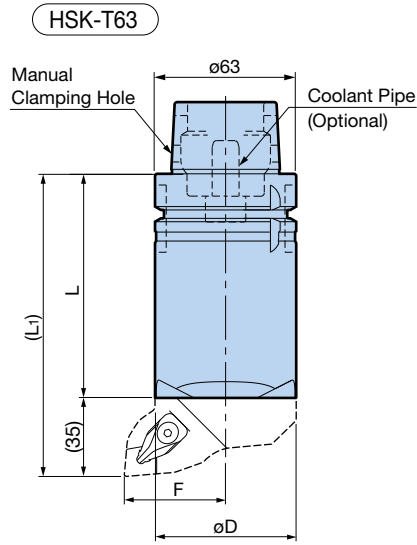

Fig. 1

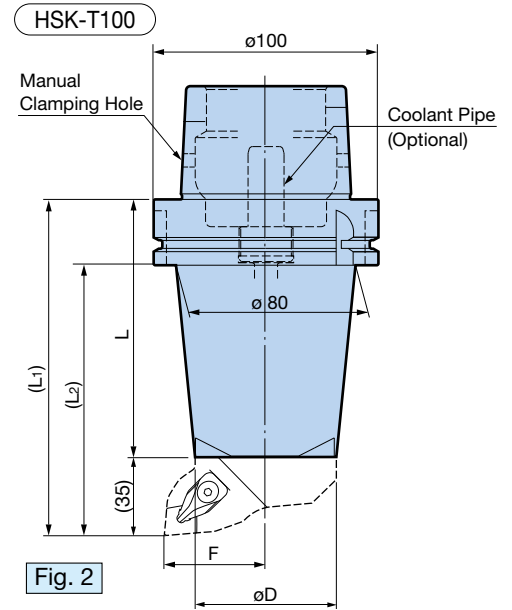

Fig. 2

Above figure shows a left-handed cartridge mounted.

Type	Model	Fig.	øD	L	(L <sub>1</sub> )	(L <sub>2</sub> )	F	Weight (kg)
F63	<b>HSK-T 63-F63- 50</b>	1	63	50	85	-	45	1.2
	<b>- 75</b>			75	110			1.8
	<b>-100</b>			100	135			2.4
	<b>-130</b>			130	165			3.1
	<b>-170</b>			170	205			4.1
F63	<b>HSK-T100-F63-100</b>	2	63	100	135	105	45	4.2
	<b>-150</b>			150	185	155		6.1

- Both M10×22L and M10×25L bolts to clamp a Cartridge are included with the basic holder.
- Hex wrench is not included.
- Coolant pipe is not included.
- The nozzle holes contain internal threads.  
Plugging one allows for ejection from the other nozzle only.

Coolant pipes **E17**

Spare parts **E7**

Cartridges **E6**

E

90° TYPE F HOLDER

For various operations including external turning, grooving and threading.

Center through

[45° Type]

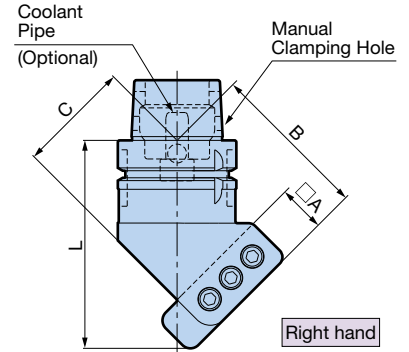

Hand	Model	□A	B	C	L	øF	Weight (kg)
<b>R</b>	<b>HSK-T63-45-BH25R-110</b>	25	85	60	110	118	2.7
<b>L</b>	<b>-BH25L-110</b>						

Right hand Left hand

Coolant pipes **E17**

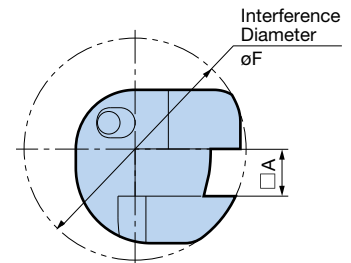

E SQUARE TOOL HOLDER

**Caution**

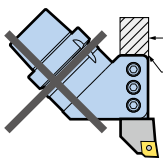

Projection prohibited

Holder end A

To avoid interference with the ATC arm, cut off the residual part of the square tool projected from the holder end A.

[90° Type]

Center through

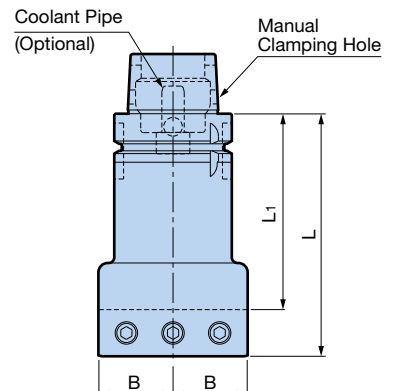

Hand	Model	□A	B	L	L <sub>1</sub>	øF	Weight (kg)
<b>N</b>	<b>HSK-T63-90-BH20N- 85</b>	20	32	85	65	80	2.2
	<b>-BH25N-100</b>	25	40	100	75	100	3.3
	<b>-BH25N-130</b>			130	105		4.0
	<b>HSK-T100-90-BH25N-150</b>	25	40	150	125	100	6.7

1. The nozzle holes contain internal threads.  
Plugging one allows for ejection from the other nozzle only.

Coolant pipes **E17**

Right/left universal

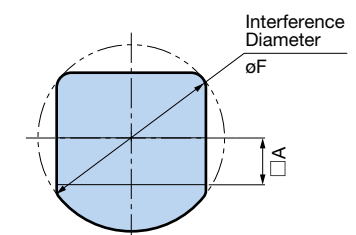

# SQUARE TOOL HOLDER

FOR EXTERNAL TURNING

DUAL CONTACT  
**HSK-T**  
SHANK

Center through

[180° Type]

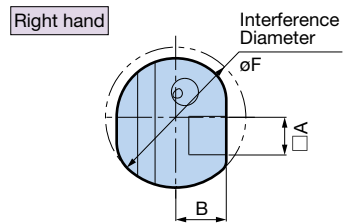
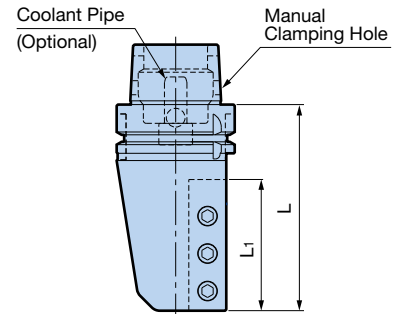

Hand	Model	□A	B	L	L <sub>1</sub>	øF	Weight (kg)
R	HSK-T 63-180-BH20R-120	20	27	120	70	75	2.7
L	-BH20L-120						
R	HSK-T 63-180-BH25R-125	25	29.5	127	80	90	3.2
L	-BH25L-125						
R	HSK-T100-180-BH25R-140	25	50	140	90	120	7.5
L	-BH25L-140						
R	HSK-T100-180-BH25R-180	25	50	180	90	120	9.7
L	-BH25L-180						

Right hand Left hand

Coolant pipes E17

E SQUARE TOOL HOLDER

[180° Multi Type]

● Mounting 3 tools minimizes ATC time.



Center through

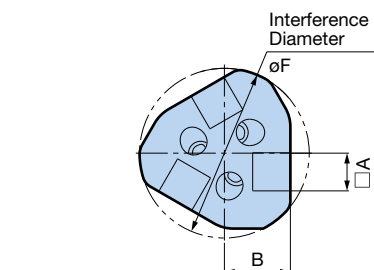
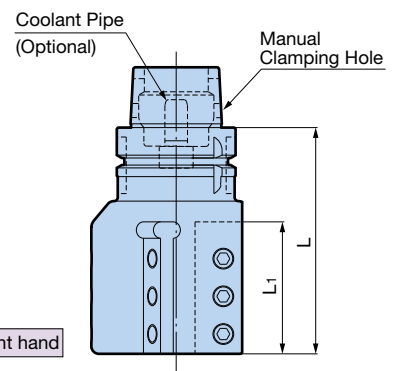

Hand	Model	□A	B	L	L <sub>1</sub>	øF	Weight (kg)
R	HSK-T63-180-3BH20R-120	20	35	120	70	90	3.3
L	-3BH20L-120						
R	HSK-T63-180-3BH25R-125	25	45	127	80	110	5.0
L	-3BH25L-125						

Right hand Left hand

Coolant pipes E17



## Caution

• 60° indexing capability is required for the machine spindle.

Center through

Holder for internal boring and threading.

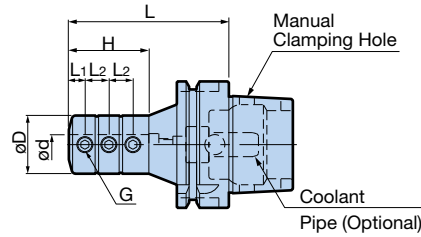

Fig. 1

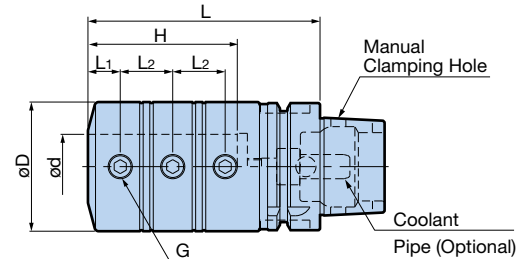

Fig. 2

Model	Fig.	$\phi d$	$\phi D$	L	L <sub>1</sub>	L <sub>2</sub>	H	Clamp Screw G	Plug A	Plug B	Weight (kg)							
<b>HSK-T 63-BSL 6- 70</b>	1	6	23	70	5	8	24	M 5 P0.8	M5 P0.8	M4 P0.7	0.9							
<b>-BSL 8- 75</b>		8	25	75	6	10	32	M 6 P1.0	M6 P1.0	M5 P0.8	0.9							
<b>-BSL10- 80</b>		10	29	80	8	12	40	M 8 P1.0		M6 P1.0	M6 P1.0	0.9						
<b>-BSL12- 85</b>		12	34	85		16	45		M10 P1.25			M6 P1.0	1.1					
<b>-BSL16- 80</b> ○		16	40	80	10	21	41	M12 P1.5		M6 P1.0	1.1							
<b>-100</b>				100			60		1.3									
<b>-BSL20- 80</b> ○ △		2	20	50	80	12	20	41	M10 P1.25	M6 P1.0	M6 P1.0	1.4						
<b>-100</b>					100			60				1.6						
<b>-BSL25- 85</b> ○			25	55	85	14	23	47	M12 P1.5	M6 P1.0	M6 P1.0	1.5						
<b>-110</b>					110			67				1.8						
<b>-BSL32- 90</b> ○ △	32		64	90	16	26	49	M16 P1.5	M6 P1.0	M6 P1.0	1.9							
<b>-125</b>				125			74				2.6							
<b>-BSL40-105</b> ○ △				40			80				105	18	32	61	M16 P1.5	M6 P1.0	M6 P1.0	2.9
<b>-145</b>											145			91				4.0
<b>-BSL50-145</b>	50		90	145	30	88	M16 P1.5	M6 P1.0	M6 P1.0	4.6								
<b>HSK-T100-BSL16-105</b>	1		16	40	105	10	21	60	M10 P1.25	M6 P1.0	M6 P1.0	2.7						
<b>-BSL20-110</b>		20	50	110	12	20	60	M12 P1.5	M6 P1.0	M6 P1.0	3.2							
<b>-BSL25-120</b>		25	55	120	14	23	67				3.5							
<b>-BSL32-125</b>		32	64	125	16	26	74	M16 P1.5	M6 P1.0	M6 P1.0	4.0							
<b>-BSL40-135</b>		40	80	135	18	32	90				5.2							
<b>-BSL50-145</b>	2	50	90	145	18	34	96	M16 P1.5	M6 P1.0	M6 P1.0	6.1							

1. Models marked with ○ come with two clamp screws.

2. △ marked models cannot be used with BSL Sleeve.

3. Plugs AB are standard accessory. ※ indicates a button head bolt.

☞ Coolant pipes **E17**

- Switchable coolant flow between side through and center through with plug screws.

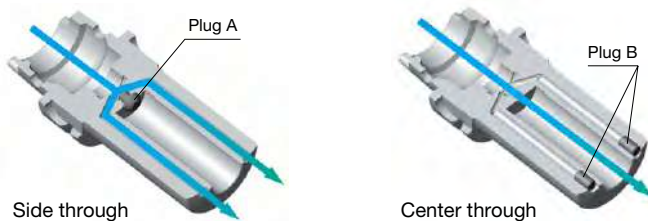

Side through

Center through

Adjustable for right or left hand operation.

For BSL SIDE LOCK HOLDER  
■ **BSL Sleeve**

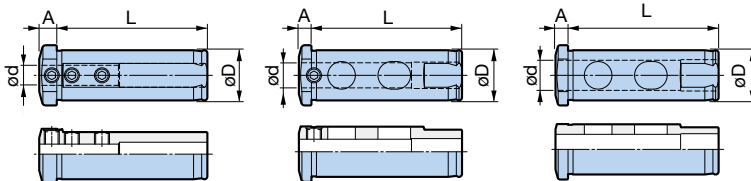

Fig. 1

Fig. 2

Fig. 3

Model	Fig.	$\phi d$	$\phi D$	L	A
<b>BSLA20- 6</b>	1	6	20	60	5
<b>- 8</b>		8			7
<b>-10</b>	2	10	20	60	5
<b>-12</b>	3	12			5
<b>-16</b>		16			5
<b>BSLA32-10</b>	1	10			32
<b>-12</b>	2	12	9		
<b>-16</b>		16	6		
<b>-20</b>	3	20	6		
<b>-25</b> <small>NEW</small>		25	6		
<b>BSLA40-16</b>	1	16	40	94	6
<b>-20</b>	3	20			6
<b>-25</b>		25			
<b>-32</b>		32			

DUAL CONTACT integrated turning adapter.  
Cartridges can be exchanged according to the machining application.

**SMART DAMPER** Turning Adapter

Center through

● Unique dynamic damper eliminates chatter!

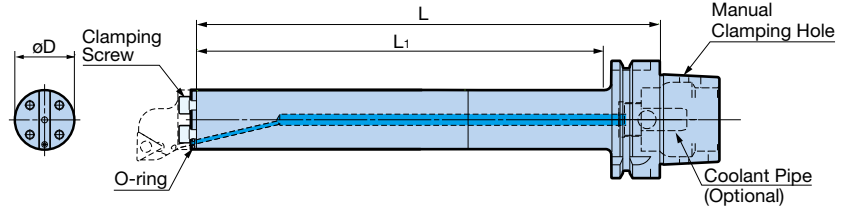

Model	Cartridge	$\varnothing D$	Min. Diameter	L	L <sub>1</sub>	Spare clamping screw (1)	Spare O-ring set (2 pcs)	Weight (kg)
<b>HSK-T63-SDB40DP-172</b>	B32-...	32	40	172	145	C0510(M5×10L)	SDB20 OR-2P	1.8
				250	219			2.3
<b>-SDB50DP-235</b>	B40-...	40	50	235	204	C0610(M6×10L)		3.3
				315	284			4.0

1. Clamping screws (3 pcs) and O-rings (2 pcs) are included.
2. Cartridges are not included. Please order separately.
3. Inserts are not included. Please order separately.
4. Coolant through is standard for all models.
5. Coolant pipe is not included. E17

**Turning Adapter**

Center through

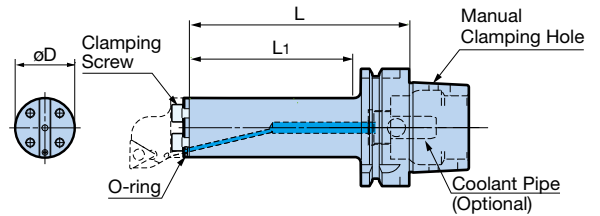

Model	Cartridge	$\varnothing D$	Min. Diameter	L	L <sub>1</sub>	Spare clamping screw (1)	Spare O-ring set (2 pcs)	Weight (kg)
<b>HSK-T63-TAD40-125</b>	B32-...	32	40	125	94	C0510(M5×10L)	SDB20 OR-2P	1.2
<b>-TAD50-155</b>	B40-...	40	50	155	124	C0610(M6×10L)		1.8

1. Clamping screws (3 pcs) and O-rings (2 pcs) are included.
2. Cartridges are not included. Please order separately.
3. Inserts are not included. Please order separately.
4. Coolant through is standard for all models.
5. Coolant pipe is not included. E17

**Cartridge** For details, see **E23 / E24**

Application	Inner flange face machining	Copy machining		Blind hole machining	
	80° rhombic	55° rhombic	35° rhombic	Triangular	
Screw-on type (for positive insert)	CC1204 	DC11T3 	VB1604 	TP1604 	TP1103 
Double clamp type (for negative insert)	CN1204 	DN1104 DN1504 DN1506 	—	—	—



## Cartridge

**[Screw-on Type]** (for positive insert)

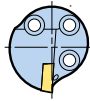

Figure shows right hand

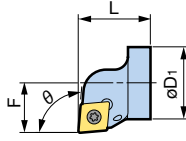

Fig. 1

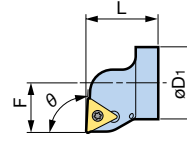

Fig. 2

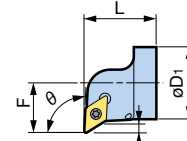

Fig. 3

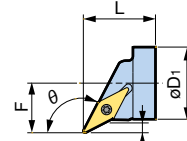

Fig. 4

Model	Fig.	Insert	Hand	øD <sub>1</sub>	F	L	Tmax.	θ	Insert Clamping Screw Set	Weight (kg)
<b>B32-SCLCR-22032-12</b>	1	CC1204	Right hand	32	22	32	-	95°	S5 S-20IP	0.1
<b>-STUCR-22032-11</b>	2	TC1102						93°	S2.5S-7IP	
<b>-STUPR-22032-16</b>		TP1604						93°	S4 S-15IP	
<b>-SDUCR-22032-11</b>	3	DC11T3						117.5°	S3.5S-15IP	
<b>-SVPBR-22032-16</b>	4	VB1604						117.5°	S3.5S-15IP	
<b>B40-SCLCR-27032-12</b>	1	CC1204	Right hand	40	27	32	-	95°	S5 S-20IP	0.2
<b>-STUCR-27032-11</b>	2	TC1102						93°	S2.5S-7IP	
<b>-STUPR-27032-16</b>		TP1604						93°	S4 S-15IP	
<b>-SDUCR-27032-11</b>	3	DC11T3						117.5°	S3.5S-15IP	
<b>-SVPBR-27032-16</b>	4	VB1604						117.5°	S3.5S-15IP	

1. A wrench and screw are included but inserts are not.
2. The insert clamping screw set (optional) contains 10 screws and 1 wrench.

E

### Insert Clamping Screw Set

Set Model	Screw	Wrench Model
<b>S2.5S- 7IP</b>	M2.5 × 6.5	FS- 7IP
<b>S3.5S-15IP</b>	M3.5 × 8	FS-15IP
<b>S4 S-15IP</b>	M4 × 8	FS-15IP
<b>S5 S-20IP</b>	M5 × 12	FS-20IP

1. Wrench is also available separately. Please order the wrench model.

TURNING ADAPTER CARTRIDGE



**[Double Clamp Type]** (for negative insert)

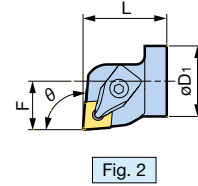
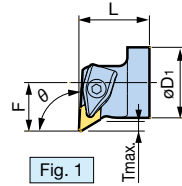
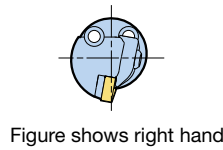

Model	Fig.	Insert	Hand	øD1	F	L	Tmax.	θ	Clamp Piece	Carbide Shim	Weight (kg)
<b>B32-DDUNR-22032-11</b>	1	DN1104	Right hand	32	22	32	4	93°	CP7	DNS1104C	0.1
<b>-DCLNR-22038-12</b>	2	CN1204				38	—	95°	CP2	CNS1204C	
<b>B40-DDUNR-27032-15</b>	1	DN1506※ (DN1504)		40	27	32	6	93°	CP2	DNS1506C (DNS1504C)	0.2
<b>-DCLNR-27038-12</b>	2	CN1204				38	—	95°	CP2	CNS1204C	

1. A carbide shim screw and wrench are included, but a clamp piece tightening wrench is not.
  2. Inserts are not included.
- ※ A carbide shim for DN1506 (thickness: 6.35mm) is included.  
When using a DN1504 insert (thickness: 4.76mm), replace the standard carbide shim with the DNS1504C (optional).

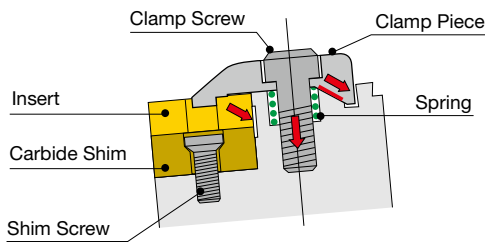

**Clamp Piece Set**

Set Model	Clamp Piece	Clamp Screw	Spring	Compatible Insert
<b>SCP2</b>	CP2	M5×20	ø8×10	CN1504, DN1506 CN1204
<b>SCP7</b>	CP7			DN1104

1. 1 pce. each of the clamp piece, clamp screw and spring are included in the set.
2. The tightening wrench is a 4mm hex wrench. T-type hex wrench is sold as Model T-4.

**Carbide Shim Set**

Compatible Insert	Set Model	Carbide Shim	Shim Screw	Torx Plus Size
DN1104	<b>SDNS1104C</b>	DNS1104C	M3×7	10IP
DN1504	<b>SDNS1504C</b>	DNS1504C	M4×8	15IP
DN1506	<b>SDNS1506C</b>	DNS1506C	M4×8	15IP
CN1204	<b>SCNS1204C</b>	CNS1204C	M4×8	15IP

1. 1 pce. each of the carbide shim and shim clamp screw are included in the set.
2. The tightening wrench is a Torx plus wrench.

**Torx Plus Wrench (optional)**

Set Model	Torx Plus Size
<b>FS-10IP</b>	10IP
<b>FS-15IP</b>	15IP

**DOUBLE-CLAMPING SYSTEM**

Double-clamping system that utilizes a “Push and Draw” mechanism to fix inserts securely

Secure insert clamping has been realized through the double-clamping system, which pushes the insert downwards while at the same time generating drawing force on the insert contact surface.

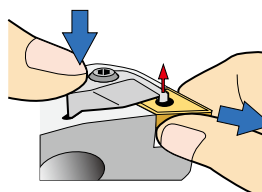

**Easy attachment and removal of inserts**

Insert attachment and removal can be performed easily by the built-in spring. Loosen the clamping screw one full rotation, lightly press the clamp piece with a finger, and its tip will pop up.

# Turning Tool System Chart

(Note) Contact us, as interference may occur depending on the machine model.

## 45°

**S Type Cartridge**  
E5

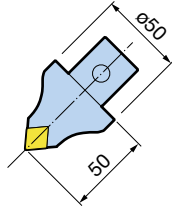

**S50** E27  
**S Type Basic Holder**

	L
C5-S50- 40	40
- 55	55
- 75	75
C6-S50- 45	45
- 75	75
-100	100
C8-S50-135	135

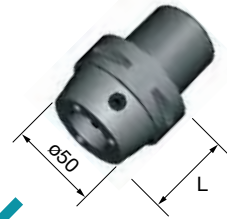

<p><b>No.1</b></p> <p><b>S50-DCLNN-00050-12</b> • Cartridge mono-block holders are also available.</p>	<p><b>No.2</b></p> <p><b>S50-DTJNR-00050-16</b> -DTJNL-00050-16 <b>S50-DTJNR-00050-22</b> -DTJNL-00050-22</p>	<p><b>No.3</b></p> <p><b>S50-DDHNN-00050-15</b> • Cartridge mono-block holders are also available. ※ When using a DN1506 insert (thickness: 6.35mm), replace the standard carbide shim with the DNS1506 (optional).</p>	<p><b>No.4</b></p> <p><b>S50-DDJNR-00050-15</b> -DDJNL-00050-15</p>	<p><b>No.5</b></p> <p><b>S50-SVQBN-00050-16</b> • Cartridge mono-block holders are also available.</p>
--	---	---	---	--

E

TURNING TOOL SYSTEM CHART

## 90°

**F50** E28  
**F Type Basic Holder**

	L
C5-F50- 25	25
- 50	50
- 85	85
-125	125

**F63** E28  
**F Type Basic Holder**

	L
C6-F63- 30	30
- 75	75
-100	100
-130	130
-170	170
C8-F63- 45	45
-100	100
-130	130
-170	170

**Mono-block Type (C3/C4)** E30

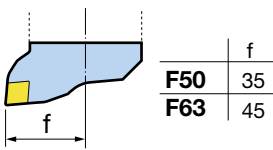

**F Type Cartridge**  
E6

<p><b>No.10</b></p> <p><b>F50-DCLNR-35035-12(16)</b> -DCLNL-35035-12(16) <b>F63-DCLNR-45035-12(16)</b> -DCLNL-45035-12(16)</p>	<p><b>No.12</b></p> <p><b>F50-DTJNR-35035-16</b> -DTJNL-35035-16 <b>F63-DTJNR-45035-16</b> -DTJNL-45035-16</p>	<p><b>No.13</b></p> <p><b>F50-DDJNR-35035-15</b> -DDJNL-35035-15 <b>F63-DDJNR-45035-15</b> -DDJNL-45035-15</p>	<p><b>No.15</b></p> <p><b>F63-SVQBR-45035-16</b> -SVQBL-45035-16</p>
--	--	--	--

※ When using a DN1506 insert (thickness: 6.35mm), replace the standard carbide shim with the DNS1506 (optional).

**Mono-block Type** **E27/E29**  
(C4/C5/C6/C8)

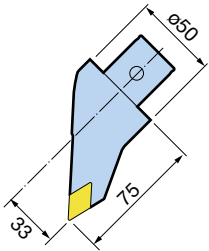

- No.1**
- No.8-1**
- No.3**
- No.5**

**S63** **E27**  
**S Type Basic Holder**

	L
<b>C6-S63- 90</b>	90
<b>C8-S63-125</b>	125

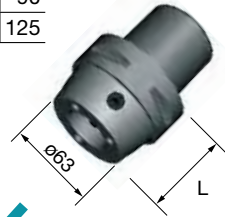
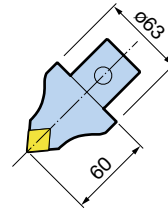

**No.6**

**S50-DDJNR-33075-15**  
**-DDJNL-33075-15**

**No.7**

**S50-SVLBR-33075-16**  
**-SVLBL-33075-16**

**No.8**

**S63-DCLNN-00060-16**  
**-DCLNN-00060-19**

• Cartridge mono-block holders are also available.

**S50/S63** **E27**  
**S Type Basic Holder**



- S Type Cartridge**  
 **E5**
- No.1**
  - No.3**
  - No.5**
  - No.8**

**Square Tool Holder**  
 **E31/E34**

**Side Lock Holder for Boring Bar**  
 **E36**

**Side Lock Drill Holder**  
 **E37**

**Morse Taper Holder**  
 **E58**

**No.18**

**F50-DDJNR-35050-15**  
**-DDJNL-35050-15**  
**F63-DDJNR-45055-15**  
**-DDJNL-45055-15**

**SMART DAMPER Turning Adapter/ Turning Adapter**  
 **E38**

**Extension** **E59** For extending tool length.

**Reduction** **E59** For reducing body diameter to avoid interference.



Basic Holder

Center through

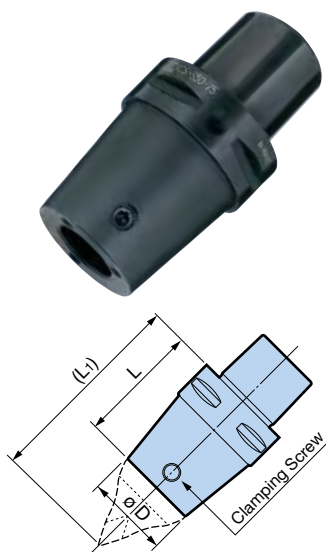

**C5/C6/C8**

Type	Model	øD	L	(L-1)	Clamping Screw	Weight (kg)
S50	<b>C5-S50- 40</b>	50	40	90	CK5S	0.6
	- 55		55	105		0.8
	- 75		75	125		1.1
S50	<b>C6-S50- 45</b>	50	45	95	CK5S	1.0
	- 75		75	125		1.5
	-100		100	150		2.0
S63	<b>-S63- 90</b>	63	90	150	CK6S	2.1
S50	<b>C8-S50-135</b>	50	135	185	CK5S	4.0
S63	<b>-S63-125</b>	63	125	185	CK6S	4.2

1. Clamping screw is included with the basic holder.

Spare parts **E7**

Cartridges **E5**

Mono-block Holder

Center through

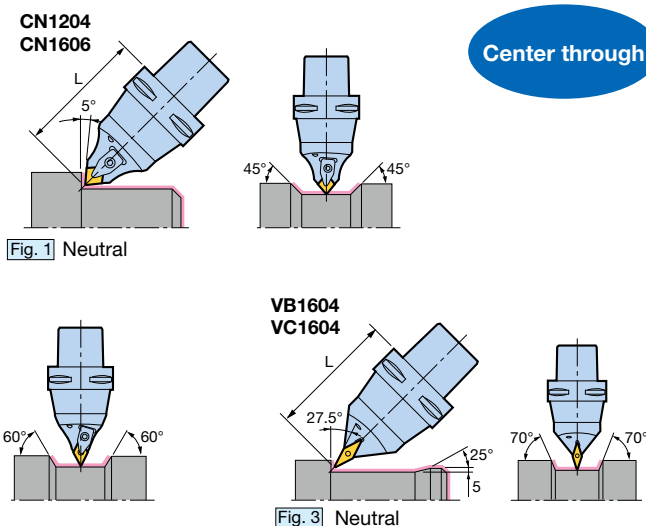

**C5/C6/C8**

Entering angle	No.	Hand	Model	Fig.	L	Insert	Clamp Piece	Weight (kg)		
95°	No.1	N	<b>C5-DCLNN-00105-12</b>	1	105	CN1204 Rhombic 80°	CP2	1.3		
	No.8-1		<b>-DCLNN-00105-16</b>			CN1606 Rhombic 80°	CP3	1.4		
107.5°	No.3		<b>-DDHNN-00105-15</b>	2		DN1504 <sup>※1</sup> (DN1506) Rhombic 55°	CP2	1.3		
117.5°	No.5		<b>-SVQBN-00105-16</b>	3		VB1604 <sup>※2</sup> (VC1604) Rhombic 35°	M3.5 <sup>※3</sup>	1.1		
95°	No.1		N	<b>C6-DCLNN-00115-12</b>		1	115	CN1204 Rhombic 80°	CP2	1.9
	No.8-1			<b>-DCLNN-00115-16</b>				CN1606 Rhombic 80°	CP3	2.0
107.5°	No.3	<b>-DDHNN-00115-15</b>		2	DN1504 <sup>※1</sup> (DN1506) Rhombic 55°	CP2		1.9		
117.5°	No.5	<b>-SVQBN-00115-16</b>		3	VB1604 <sup>※2</sup> (VC1604) Rhombic 35°	M3.5 <sup>※3</sup>		1.7		
95°	No.1	N		<b>C8-DCLNN-00150-12</b>	1	150		CN1204 Rhombic 80°	CP2	4.0
	No.8-1			<b>-DCLNN-00150-16</b>				CN1606 Rhombic 80°	CP3	4.1
107.5°	No.3		<b>-DDHNN-00150-15</b> <b>NEW</b>	2	DN1504 <sup>※1</sup> (DN1506) Rhombic 55°		CP2	4.0		

1. Insert is not included.

Spare parts **E7**

※1 A carbide shim for DN1504 (thickness: 4.76mm) is included. When using a DN1506 insert (thickness: 6.35mm), replace with the DNS1506 carbide shim (optional).

※2 Either VB1604 or VC1604 insert can be mounted. ※3 M3.5 is a screw-on type.

Neutral

## Basic Holder

Center through

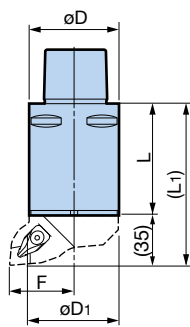

Above figure shows a left-handed cartridge mounted.

**C5/C6/C8**

Type	Model	øD	øD <sub>1</sub>	L	(L <sub>1</sub> )	F	Weight (kg)
F50	<b>C5-F50- 25</b>	50	50	25	60	35	0.5
	- 50			50	85		0.9
	- 85			85	120		1.4
	-125			125	160		2.0
F63	<b>C6-F63- 30</b>	63	63	30	65	45	0.9
	- 75			75	110		2.0
	-100			100	135		2.6
	-130			130	165		3.3
	-170			170	205		4.2
F63	<b>C8-F63- 45</b>	80	63	45	80	45	2.1
	-100			100	135		3.7
	-130			130	165		4.5
	-170			170	205		5.6

- Both M10×22L and M10×25L bolts to clamp a Cartridge are included with the basic holder.
- Hex wrench is not included.
- The nozzle holes contain internal threads.  
Plugging one allows for ejection from the other nozzle only.

 Spare parts **E7**

 Cartridges **E6**
**E**

90° TYPE F HOLDER

Mono-block Holder

Center through

- Coolant supplied from 2 locations.

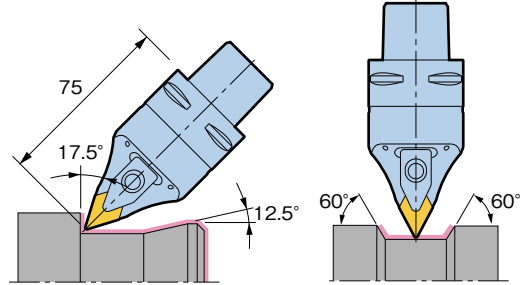

**C4**

Entering angle	No.	Hand	Model	Insert	Clamp Piece	Weight (kg)
107.5°	No.3	N	C4-DDHNN-00075-15 <b>NEW</b>	DN1504*1 (DN1506) Rhombic 55°	CP2*2	0.53

1. Insert is not included.

Spare parts **E7**

※1 A carbide shim for DN1504 (thickness: 4.76mm) is included.

When using a DN1506 insert (thickness: 6.35mm), replace the standard carbide shim with the DNS1506 (optional).

※2 Clamp Piece Set: Use SCP2S.

Neutral

Mono-block Holder

Center through

- Tough and reliable insert clamp enables highly efficient cutting.

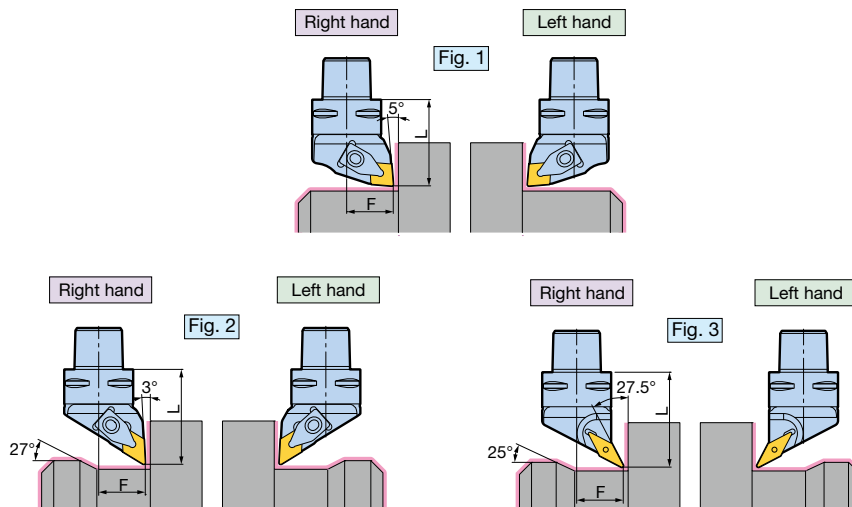

**C3/C4**

Entering angle	No.	Hand	Model	Fig.	L	F	Insert	Clamp Piece	Weight (kg)
95°	No.19	R	C3-DCLNR-22038-09	1	38	22	CN0903 <sup>※1</sup> Rhombic (CN0904) Type 80°	CP7	0.20
		L	-DCLNL-22038-09						
93°	No.20	R	-DDJNR-22045-11	2	45	22	DN1104 Rhombic Type 55°	CP7	0.20
		L	-DDJNL-22045-11						
117.5°	No.21	R	-SVQBR-22038-11	3	38	22	VB1103 <sup>※2</sup> Rhombic (VC1103) Type 35°	M2.5 <sup>※5</sup>	0.16
		L	-SVQBL-22038-11						
95°	No.10-1	R	C4-DCLNR-27050-12	1	50	27	CN1204 Rhombic Type 80°	CP2	0.44
		L	-DCLNL-27050-12						
93°	No.18	R	-DDJNR-27055-15	2	55	27	DN1504 <sup>※3</sup> Rhombic (DN1506) Type 55°	CP2	0.41
		L	-DDJNL-27055-15						
117.5°	No.15	R	-SVQBR-27055-16	3	55	27	VB1604 <sup>※4</sup> Rhombic (VC1604) Type 35°	M3.5 <sup>※5</sup>	0.39
		L	-SVQBL-27055-16						

1. Wrench is not included with the holder.
2. Insert is not included.

Spare parts **E7**

- ※1 A carbide shim for CN0903 (thickness: 3.18mm) is included. When using a CN0904 Insert (thickness: 4.76mm), replace the standard carbide shim with the CNS0904C (optional).
- ※2 Either VB1103 or VC1103 insert can be mounted.
- ※3 A carbide shim for DN1504 (thickness: 4.76mm) is included. When using a DN1506 insert (thickness: 6.35mm), replace the standard carbide shim with the DNS1506 (optional).
- ※4 Either VB1604 or VC1604 insert can be mounted.
- ※5 M2.5 and M3.5 is a screw-on type.

Right hand      Left hand

[90° Type]

Center through



Right hand



Left hand

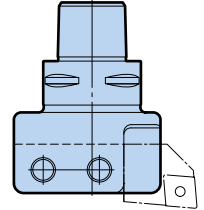
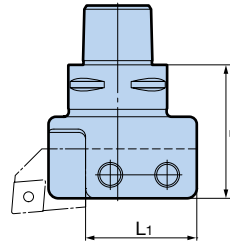

**C3/C4**

Hand	Model	A	B <sub>1</sub>	B <sub>2</sub>	L	L <sub>1</sub>	øF	Weight (kg)
R	C3-90-BH16R-2547	16	27	25	47	40	70	0.63
L	-BH16L-2547							
R	C4-90-BH20R-2854	20	32	28	54	45	80	0.95
L	-BH20L-2854							

Right hand      Left hand

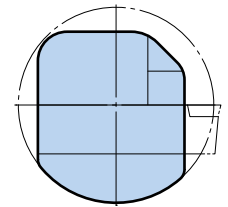
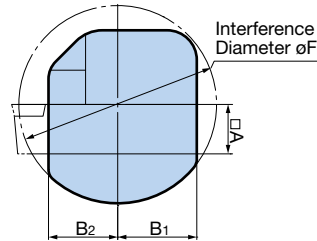

SQUARE TOOL HOLDER



[180° Type]

Center through

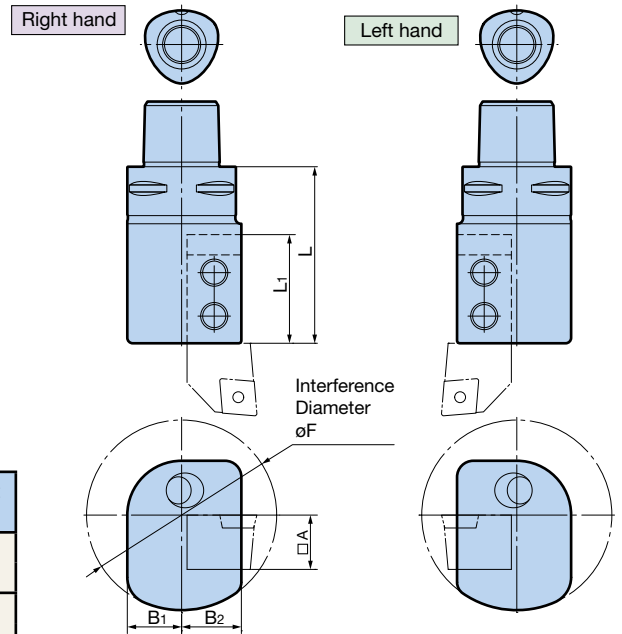

**C3/C4**

Hand	Model	A	B <sub>1</sub>	B <sub>2</sub>	L	L <sub>1</sub>	øF	Weight (kg)
R	C3-180-BH16R-2058	16	18.5	20	58	37	65	0.60
L	-BH16L-2058							
R	C4-180-BH20R-2265	20	20	22	65	40	70	0.85
L	-BH20L-2265							

Right hand      Left hand

Internal boring and threading tool holder.

Center through

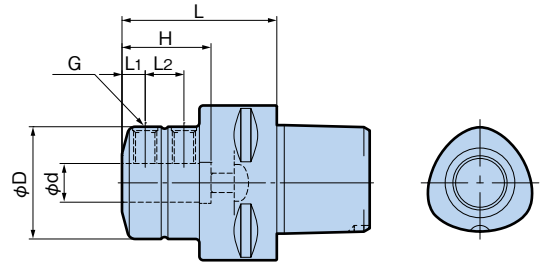

## C3/C4

Model	$\phi d$	$\phi D$	L	L <sub>1</sub>	L <sub>2</sub>	H	Clamp Screw G	Plug A	Plug B	Weight (kg)
<b>C3-BSL 6-35</b>	6	23	35	5	9	22	M 5 P0.8	M5 P0.8	M4 P0.7	0.17
<b>-BSL 8-35</b>	8	25		6	10		M 6 P1.0			0.18
<b>-BSL10-35</b>	10	29		8	12		M 8 P1.0			0.20
<b>-BSL12-40</b>	12	34	40	8	12	27	M 8 P1.0			0.26
<b>C4-BSL 6-40</b>	6	23	40	5	9	23	M 5 P0.8	M5 P0.8	M4 P0.7	0.32
<b>-BSL 8-40</b>	8	25		6	10		M 6 P1.0			0.31
<b>-BSL10-40</b>	10	29		8	12		M 8 P1.0			0.34
<b>-BSL12-45</b>	12	34	45	8	12	28	M 8 P1.0			0.38
<b>-BSL16-50</b>	16	40	50	10	14	33	M10 P1.25	M6 P1.0		0.48
<b>-BSL20-60</b>	20	50	60	12	15	43				

- BSL Sleeve cannot be used.
- Plugs AB are included. Plug A is a button head bolt.

● Switchable coolant flow between side through and center through with plug screws.

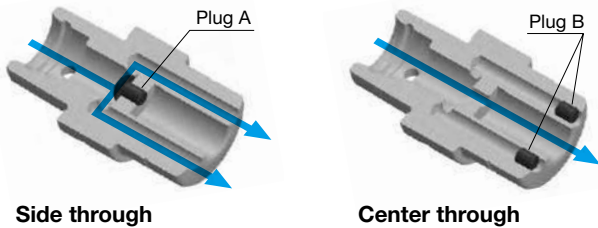

Adjustable for right or left hand operation.

SIDE LOCK HOLDER FOR BORING BAR

E

**[45° Type]**

● For various operations including external turning, grooving and threading.



Center through

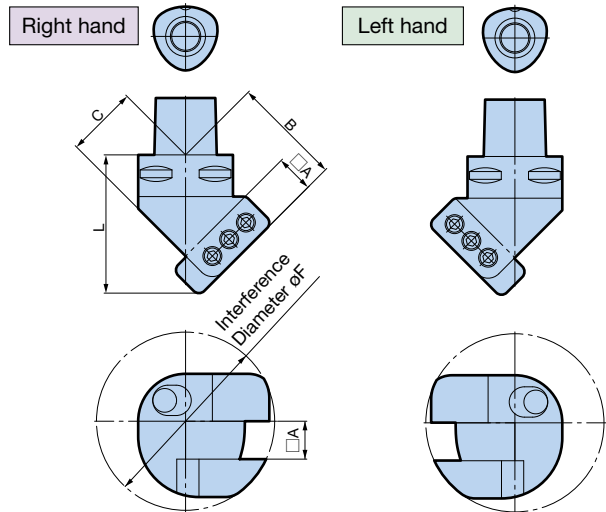

**C5/C6/C8**

Hand	Model	A	B	C	L	øF	Weight (kg)
R	C5-45-BH20R- 5838	20	58	38	73	94	1.2
L	-BH20L- 5838						
R	C6-45-BH25R- 7752	25	77	52	100	118	2.5
L	-BH25L- 7752						
R	C8-45-BH32R-85109	32	85	109	145	135	7.3
L	-BH32L-85109						

Right hand Left hand

**Caution**

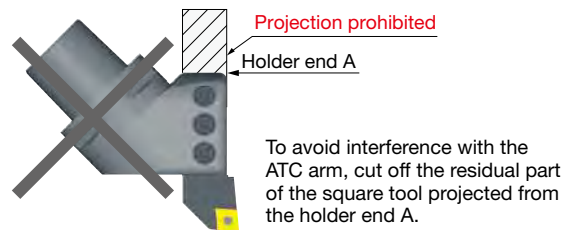

**[90° Type]**



Center through

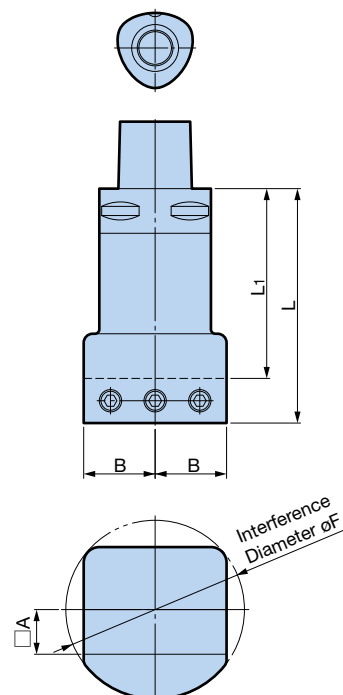

**C5/C6/C8**

Hand	Model	A	B	L	L <sub>1</sub>	øF	Weight (kg)
N	C5-90-BH20N-32058	20	32	58	38	80	0.9
	-32105			105	85		2.2
N	C6-90-BH20N-32060	20	32	60	40	80	2.4
	-32115			115	95		3.4
N	-BH25N-40071	25	40	71	46	100	3.3
	-40130			130	105		4.2
N	C8-90-BH32N-51085	32	51	85	53	128	6.0
	-51165			165	133		8.7

1. Plug one of the two coolant nozzles with a countersunk head screw (M3.5 or M5) when only one nozzle is required.

Neutral

[180° Type]

Center through

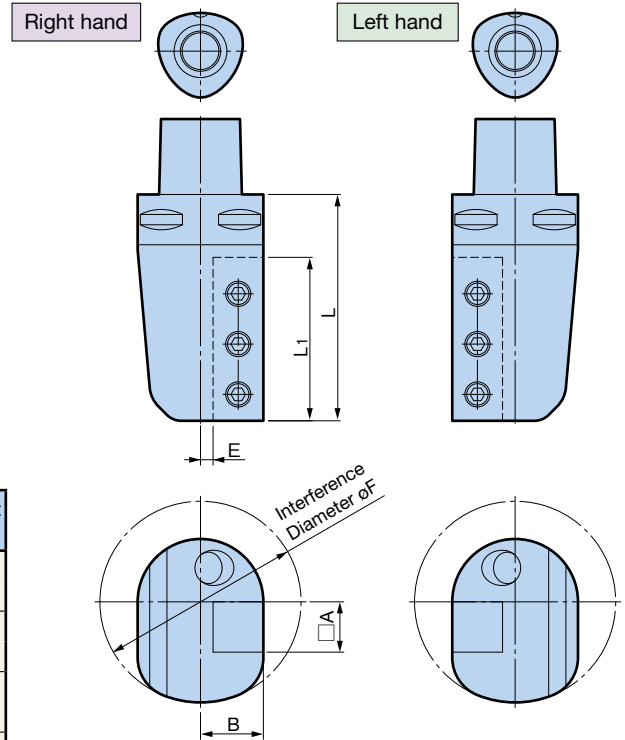

C5/C6/C8

Hand	Model	□ A	B	L	L <sub>1</sub>	E	øF	Weight (kg)
R	C5-180-BH20R- 2590	20	25	90	65	5	80	1.6
L	-BH20L - 2590							
R	C6-180-BH20R-32100	20	31.5	100	65	11.5	80	2.6
L	-BH20L -32100							
R	-BH25R-32120S	25	29.5	120	80	4.5	90	3.1
L	-BH25L -32120S							
R	C8-180-BH32R-40125	32	40	125	85	8	128	6.0
L	-BH32L -40125							

Right hand Left hand

[180° Multi Type]

Center through

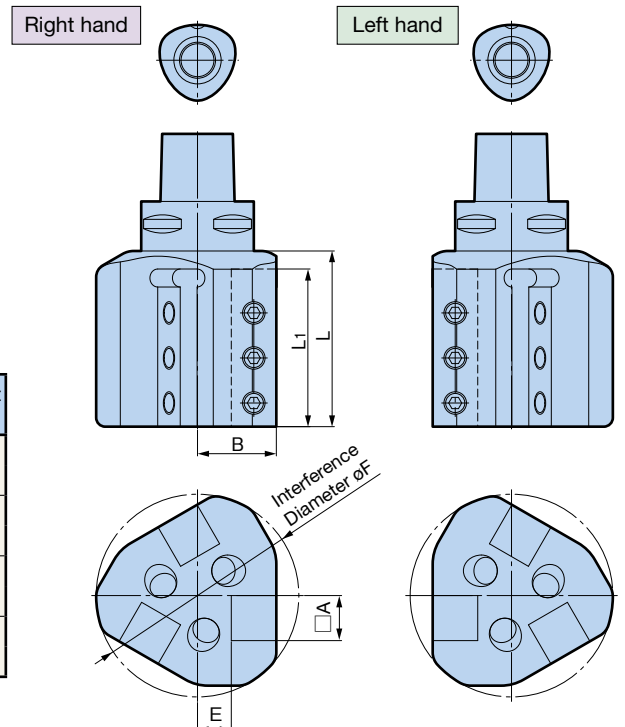

C5/C6/C8

Hand	Model	□ A	B	L	L <sub>1</sub>	E	øF	Weight (kg)
R	C5-180-3BH20R-100	20	35	100	70	15	90	2.6
L	-3BH20L-100							
R	C6-180-3BH20R-110	20	35	110	70	15	90	3.3
L	-3BH20L-110							
R	-3BH25R-125	25	45	125	80	20	110	5.0
L	-3BH25L-125							
R	C8-180-3BH25R-130	25	45	130	90	20	110	6.1
L	-3BH25L-130							

Right hand Left hand



**Caution**

•60° indexing capability is required for the machine spindle.

Holder for internal boring and threading tool.

Center through

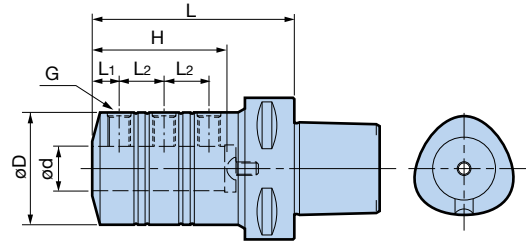

## C5/C6/C8

Model	$\phi d$	$\phi D$	L	L <sub>1</sub>	L <sub>2</sub>	H	Clamp Screw G	Plug A	Plug B	Weight (kg)
<b>C5-BSL 6- 70</b>	6	23	70	5	8	41	M 5 P0.8	M 8 P1.25	M4 P0.7	0.6
<b>-BSL 8- 70</b>	8	25		6	10		M 6 P1.0	M10 P1.5		
<b>-BSL10- 70</b>	10	29		8	12		M 8 P1.0	M12 P1.5		
<b>-BSL12- 80</b>	12	34	80	16	53	M10 P1.25	M14 P1.5	M6 P1.0	0.8	
<b>-BSL16- 90</b>	16	40	90	10	21		65		1.0	
<b>-BSL20- 90</b>	20	50		12	20		60		1.3	
<b>-BSL25-100</b>	25	55		100	14	23	70	1.6		
<b>-BSL32-110</b>	32	64	110	16	26	78	M12 P1.5	*M 8 P1.25	2.1	
<b>-BSL40-130</b>	40	80	130	18	32	93			3.7	
<b>-BSL40-130</b>	40	80	130	18	32	93			M16 P1.5	3.7
<b>C6-BSL 6- 70</b>	6	23	70	5	8	41	M 5 P0.8	M 8 P1.25	M4 P0.7	1.4
<b>-BSL 8- 70</b>	8	25		6	10		M 6 P1.0	M10 P1.5		
<b>-BSL10- 70</b>	10	29		8	12		M 8 P1.0	M12 P1.5		
<b>-BSL12- 80</b>	12	34	80	16	53	M10 P1.25	M14 P1.5	M6 P1.0	1.5	
<b>-BSL16- 90</b>	16	40	90	10	21		65		M18 P1.5	1.7
<b>-BSL20- 90</b>	20	50		12	22		60		*M 6 P1.0	2.0
<b>-BSL25-100</b>	25	55		100	14	23	70	M12 P1.5	*M 8 P1.25	2.3
<b>-BSL32-110</b>	32	64	110	16	26	78	2.8			
<b>-BSL40-130</b>	40	80	130	18	32	93	4.3			
<b>-BSL50-135</b>	50	90	135	30	88	M16 P1.5		4.5		
<b>C8-BSL16- 90</b>	16	40	90	10	21	65	M10 P1.25	M18 P1.5	M6 P1.0	2.9
<b>-BSL20-100</b>	20	50	100	12	22	70		*M 6 P1.0		3.3
<b>-BSL25-110</b>	25	55	110	14	26	80		M12 P1.5		*M 8 P1.25
<b>-BSL32-120</b>	32	64	120	16	30	88	4.1			
<b>-BSL40-130</b>	40	80	130	18	32	93	5.3			
<b>-BSL50-140</b>	50	90	140	36	105	M16 P1.5	M10 P1.5	5.4		

1. Plugs AB are included. \* indicates a button head bolt.

- Switchable coolant flow between side through and center through with plug screws.

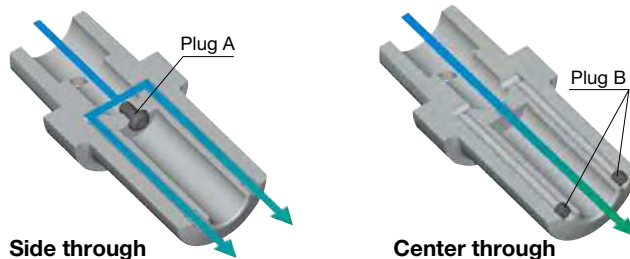

Adjustable for right or left hand operation.

For BSL SIDE LOCK HOLDER

### BSL Sleeve

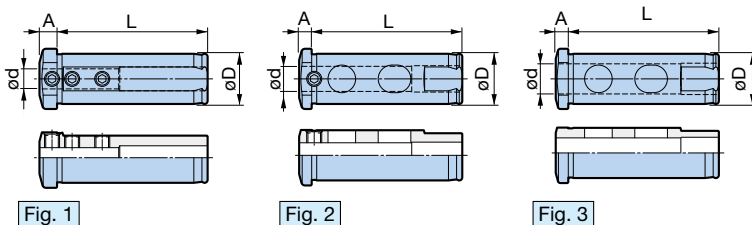

Model	Fig.	$\phi d$	$\phi D$	L	A
<b>BSLA20- 6</b>	1	6	20	60	5
<b>- 8</b>		8			7
<b>-10</b>		10			5
<b>-12</b>	3	12	32	75	5
<b>-16</b>		16			5
<b>BSLA32-10</b>	1	10	40	94	9
<b>-12</b>		12			9
<b>-16</b>		16			6
<b>-20</b>	3	20	32	75	6
<b>-25</b> <small>NEW</small>		25			6
<b>BSLA40-16</b>	1	16	40	94	6
<b>-20</b>		20			
<b>-25</b>		25			
<b>-32</b>	3	32			

Basic holder for indexable insert drills.

Center through

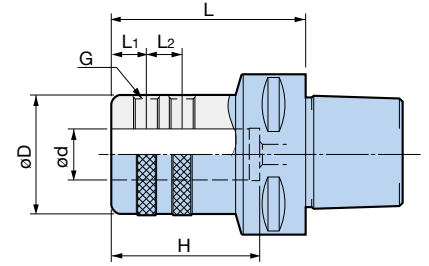

**C5/C6/C8**

Model	$\varnothing d$	$\varnothing D$	L	L <sub>1</sub>	L <sub>2</sub>	H	Clamp Screw G	Weight (kg)
<b>C5-TSL16-60</b>	16	48	60	14	14	48	M10 P1.25	0.8
<b>-TSL20-60</b>	20					50		
<b>-TSL25-75</b>	25					75		
<b>-TSL32-85</b>	32	63	85	15	20	56	M16 P1.5	0.9
					60	1.6		
<b>C6-TSL16-70</b>	16	48	70	14	14	48	M10 P1.25	1.7
<b>-TSL20-70</b>	20					50		
<b>-TSL25-70</b>	25					56		
<b>-TSL32-75</b>	32	63	75	15	20	60	M16 P1.5	2.0
<b>-TSL40-85</b>	40	68	85	25	70	2.2		
<b>C8-TSL16-80</b>	16	48	80	14	14	48	M10 P1.25	3.1
<b>-TSL20-80</b>	20					50		
<b>-TSL25-85</b>	25					85		
<b>-TSL32-90</b>	32	63	90	15	20	60	M16 P1.5	3.5
<b>-TSL40-95</b>	40	68	95	25	70	3.5		

1. Center through coolant supply is available.

For SIDE LOCK DRILL HOLDER

**SL Sleeve**

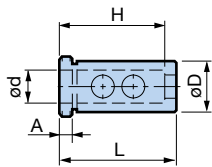

Model	$\varnothing d$	$\varnothing D$	L	A	H
<b>OSL25-16</b>	16	25	62	5.5	48
<b>-20</b>	20				50
<b>OSL32-16</b>	16	32	66	5.5	48
<b>-20</b>	20				50
<b>-25</b>	25				56
<b>OSL40-16</b>	16	40	76	5.5	48
<b>-20</b>	20				50
<b>-25</b>	25				56
<b>-32</b>	32				60

SIDE LOCK HOLDER FOR BORING BAR

E

DUAL CONTACT integrated turning adapter.  
Cartridges can be exchanged according to the machining application.

**SMART DAMPER Turning Adapter**

Center through

● Unique dynamic damper eliminates chatter!

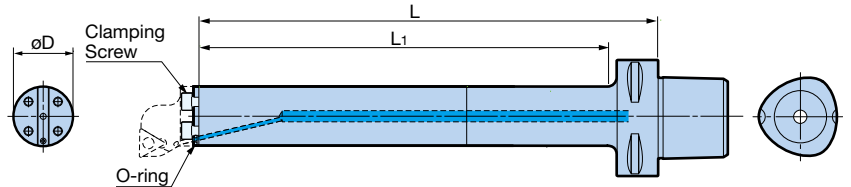

**C6**

Model	Cartridge	$\varnothing D$	Min. Diameter	L	L <sub>1</sub>	Spare clamping screw (1)	Spare O-ring set (2 pcs)	Weight (kg)
<b>C6-SDB40DP-168</b>	B32-...	32	40	168	145	C0510(M5×10L)	SDB20 OR-2P	1.9
				-245	218			2.4
<b>50DP-230</b>	B40-...	40	50	230	203	C0610(M6×10L)		3.4
				-310	283			4.1

1. Clamping screws (3 pcs) and O-rings (2 pcs) are included.
2. Cartridges are not included. Please order separately.
3. Inserts are not included. Please order separately.
4. Coolant through is standard for all models.

**Turning Adapter**

Center through

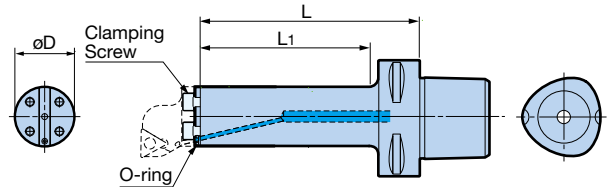

**C6**

Model	Cartridge	$\varnothing D$	Min. Diameter	L	L <sub>1</sub>	Spare clamping screw (1)	Spare O-ring set (2 pcs)	Weight (kg)
<b>C6-TAD40-120</b>	B32-...	32	40	120	93	C0510(M5×10L)	SDB20 OR-2P	1.3
<b>-TAD50-150</b>	B40-...	40	50	150	123	C0610(M6×10L)		1.9

1. Clamping screws (3 pcs) and O-rings (2 pcs) are included.
2. Cartridges are not included. Please order separately.
3. Inserts are not included. Please order separately.
4. Coolant through is standard for all models.

**Cartridge**

For details, see **E23 / E24**

Application	Inner flange face machining	Copy machining		Blind hole machining	
	80° rhombic	55° rhombic	35° rhombic	Triangular	
Screw-on type (for positive insert)	CC1204	DC11T3	VB1604	TP1604	TP1103
Double clamp type (for negative insert)	CN1204	DN1104 DN1504 DN1506			





Ultra-slim design with  $\varnothing 10\text{mm}$  nut outer diameter.  
High speed collet chuck with minimized interference.

**[High Rigidity Taper Type]**

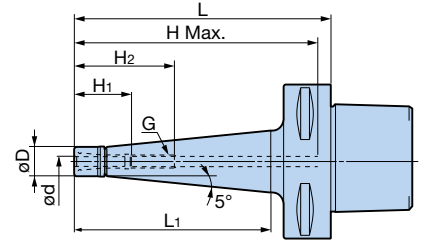
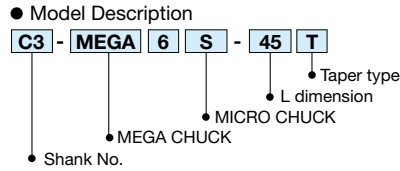

**C3/C4/C5/C6**

Model	Clamping diameter $\varnothing d$	$\varnothing D$	L	L <sub>1</sub>	H <sub>1</sub>	H <sub>2</sub>	H Max.	G	Collet Model	Weight (kg)
<b>C3-MEGA6S- 45T</b> <small>NEW</small>	0.45 - 6.05	14	45	27	28	—	39	—	NBC6S-□	0.15
<b>C4-MEGA3S- 60T</b>	0.45 - 3.25	10	60	35	22	38	54	M4 P0.7	NBC3S-□	0.28
<b>-MEGA6S- 60T</b>	0.45 - 6.05	14	60	35	28	47	54	M7 P0.75	NBC6S-□	0.29
<b>- 90T</b>			90	65		48	84			0.36
<b>C5-MEGA3S-105T</b>	0.45 - 3.25	10	105	79	22.5	38.5	98	M4 P0.7	NBC3S-□	0.5
<b>-MEGA4S-105T</b>	0.45 - 4.05	12	105	79	26.5	47	98	M5 P0.8	NBC4S-□	0.5
<b>-120T</b>			120	94			113			0.6
<b>-MEGA6S-105T</b>	0.45 - 6.05	14	105	79	28.5	49	98	M7 P0.75	NBC6S-□	0.6
<b>-120T</b>			120	94			113			0.6
<b>C6-MEGA3S-120T</b>	0.45 - 3.25	10	120	92	22.5	38.5	111	M4 P0.7	NBC3S-□	1.3
<b>-MEGA4S-120T</b>	0.45 - 4.05	12	120	92	26.5	47	111	M5 P0.8	NBC4S-□	1.3
<b>-135T</b>			135	107			126			1.4
<b>-MEGA6S-120T</b>	0.45 - 6.05	14	120	92	28.5	49	111	M7 P0.75	NBC6S-□	1.3
<b>-135T</b>			135	107			126			1.4

- Nut is included. Collet and wrench must be ordered separately.
- Weight includes the nut but not the collet.
- Models marked with ※ do not have inner thread.
- Please note that the practical spindle speed may be considerably influenced by the machine rigidity and tool balance. When using, slowly ramp up to the appropriate speed starting from slow speeds.

**[Straight Type]**

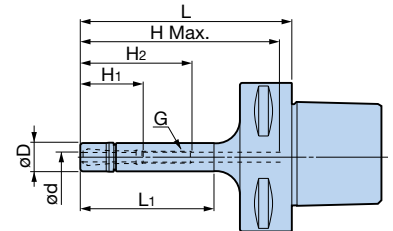
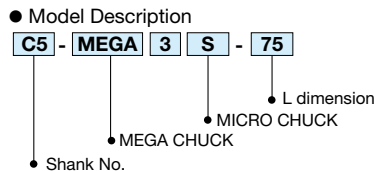

**C5/C6**

Model	Clamping diameter $\varnothing d$	$\varnothing D$	L	L <sub>1</sub>	H <sub>1</sub>	H <sub>2</sub>	H Max.	G	Collet Model	Weight (kg)
<b>C5-MEGA3S-75</b>	0.45 - 3.25	10	75	49	22.5	38	68	M4 P0.7	NBC3S-□	0.4
<b>-MEGA4S-75</b>	0.45 - 4.05	12		50	26.5	47		M5 P0.8	NBC4S-□	0.4
<b>-MEGA6S-75</b>	0.45 - 6.05	14		50	28.5	49		M7 P0.75	NBC6S-□	0.4
<b>C6-MEGA3S-90</b>	0.45 - 3.25	10	90	50	22.5	38	81	M4 P0.7	NBC3S-□	1.1
<b>-MEGA4S-90</b>	0.45 - 4.05	12		58	26.5	47		M5 P0.8	NBC4S-□	1.2
<b>-MEGA6S-90</b>	0.45 - 6.05	14		58	28.5	49		M7 P0.75	NBC6S-□	1.2

- Nut is included. Collet and wrench must be ordered separately.
- Weight includes the nut but not the collet.
- Please note that the practical spindle speed may be considerably influenced by the machine rigidity and tool balance. When using, slowly ramp up to the appropriate speed starting from slow speeds.

Standard Accessory	Optional Accessories				
<b>MEGA NUT</b> <p>For Spares <b>G6</b></p>	<b>Mega Wrench</b> <p><b>G33</b></p>	<b>Micro Collet</b> <p><b>G4</b></p>	<b>Mega Micro Seal Nut (For 6S)</b> <b>Mega Micro Coolant Nut (For 6S)</b> <p><b>G6</b></p>	<b>Collet Case</b> <p><b>G6</b></p>	<b>Adjusting Screw</b> <p><b>G23</b></p>



Clamping diameter:  $\varnothing 0.25 - \varnothing 20$ **MEGA NEW BABY CHUCK**

High speed and reliable machining are achieved with the exceptional tool balance and high precision collet chuck system.

Center through

Max.  
**35,000min<sup>-1</sup>**

## ● Model Description

**C3 - MEGA 6 N - 45**

- L dimension
- NEW BABY CHUCK
- Maximum clamping diameter
- MEGA CHUCK
- Shank No.

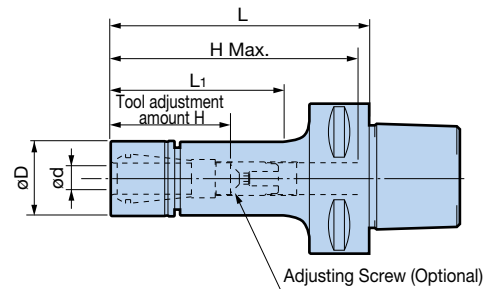
**C3/C4/C5**

Model	Clamping diameter $\varnothing d$	$\varnothing D$	L	L <sub>1</sub>	H	H Max.	Collet Model	Weight (kg)
<b>C3 - MEGA 6N- 45</b> ※	0.25 - 6	20	45	28	23	23	NBC 6-□	0.17
<b>-MEGA 8N- 45</b> ※	0.5 - 8	25	45	28	26	26	NBC 8-□	0.21
<b>-MEGA10N- 50</b> ※	1.5 - 10	30	50	34	38	38	NBC10-□	0.24
<b>-MEGA13N- 50</b> ※	2.5 - 13	35	50	35	44	44	NBC13-□	0.27
<b>-MEGA16N- 55</b> ※	2.5 - 16	42	55	—	49	49	NBC16-□	0.34
<b>C4 - MEGA 6N- 75</b>	0.25 - 6	20	75	48	23 - 43	69	NBC 6-□	0.36
<b>-MEGA 8N- 75</b>	0.5 - 8	25	75	49	26 - 45	69	NBC 8-□	0.41
<b>-MEGA10N- 50</b> ※	1.5 - 10	30	50	28	44	44	NBC10-□	0.35
<b>- 75</b>			75	52	38 - 48	69		0.60
<b>-MEGA13N- 50</b> ※	2.5 - 13	35	50	29	44	44	NBC13-□	0.37
<b>- 75</b> ※			75	54	64	64		0.47
<b>-MEGA16N- 55</b> ※	2.5 - 16	42	55	—	48	48	NBC16-□	0.45
<b>-MEGA20N- 60</b> ※	2.5 - 20	46	60	—	53	53	NBC20-□	0.54
<b>C5 - MEGA 6N- 60</b>	0.25 - 6	20	60	34	23 - 43	53	NBC 6-□	0.5
<b>- 75</b>			75	49		68		0.5
<b>- 90</b>			90	62		83		0.5
<b>-105</b>			105	77		98		0.6
<b>-120</b>			120	90		113		0.6
<b>-MEGA 8N- 60</b>			60	33		26 - 36		53
<b>- 75</b>	75	49	26 - 45	68	0.6			
<b>- 90</b>	90	64	83	0.6				
<b>-105</b>	105	77	98	0.7				
<b>-120</b>	120	92	113	0.7				
<b>-MEGA10N- 55</b> ※	55	31	48	48	NBC10-□	0.5		
<b>- 75</b>	75	49	68	0.6				
<b>- 90</b>	90	64	83	0.7				
<b>-105</b>	105	79	98	0.8				
<b>-120</b>	120	92	113	0.9				
<b>-MEGA13N- 55</b> ※	55	31	48	48		NBC13-□	0.6	
<b>- 75</b>	75	49	44 - 48	68	0.7			
<b>- 90</b>	90	64	83	0.8				
<b>-105</b>	105	79	44 - 63	98	0.9			
<b>-120</b>	120	94	113	1.0				
<b>-MEGA16N- 60</b> ※	60	38	53	53	NBC16-□		0.7	
<b>- 75</b> ※	75	53	68	68		0.9		
<b>- 90</b>	90	69	48 - 63	83		1.0		
<b>-105</b>	105	84	98	1.1				
<b>-120</b>	120	99	48 - 68	111		1.3		
<b>-MEGA20N- 60</b> ※	60	39	51	51		NBC20-□	0.8	
<b>- 75</b> ※	75	54	66	66	1.0			
<b>- 90</b>	90	69	51 - 60	83	1.1			
<b>-105</b>	105	84	98	1.3				
<b>-120</b>	120	99	51 - 68	111	1.4			

- Nut is included. Adjusting Screw, collet and wrench must be ordered separately.
- Weight includes the nut but not the collet.
- Center through coolant supply is available.
- ※ marked models cannot be used with Adjusting Screws. H dimension is the max. tool shank length that can be inserted into the holder.
- Please note that the practical spindle speed may be considerably influenced by the machine rigidity and tool balance. When using, slowly ramp up to the appropriate speed starting from slow speeds.

MEGA PERFECT SEAL **G13** Collets **G7**Endmill Collets **G10** Coolant Collets **G9**

High speed and reliable machining are achieved with the exceptional tool balance and high precision collet chuck system.

Center through



● Model Description

**C6** - **MEGA** **6** **N** - **60**

- L dimension
- NEW BABY CHUCK
- Maximum clamping diameter
- MEGA CHUCK
- Shank No.

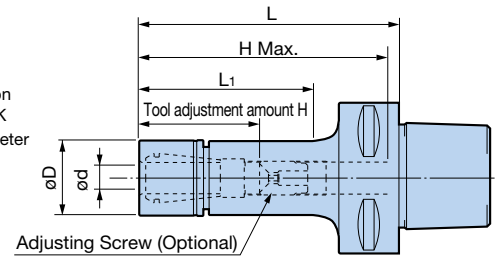

**C6**

Model	Clamping diameter $\varnothing d$	$\varnothing D$	L	L <sub>1</sub>	H	H Max.	Collet Model	Weight (kg)	
<b>C6 -MEGA 6N- 60</b>	0.25 - 6	20	60	30	23 - 33	51	NBC 6-□	1.2	
- 75			75	43	23 - 43	66		1.2	
- 90			90	58		81		1.2	
-105			105	73		96		1.3	
-120			120	88		111		1.3	
-135			135	103		126		1.3	
-165			165	128		156		1.4	
-200			200	163		191		1.5	
<b>-MEGA 8N- 60</b>	0.5 - 8	25	60	29		26 - 31	51	NBC 8-□	1.3
- 75			75	43	26 - 45	66	1.3		
- 90			90	58		81	1.3		
-105			105	73		96	1.4		
-120			120	88		111	1.4		
-135			135	103		126	1.5		
-165			165	133		156	1.6		
-200			200	163		191	1.7		
<b>-MEGA10N- 60</b> ※	1.5 - 10	30	60	32		51	51	NBC10-□	1.3
- 75			75	43	38 - 45	66	1.4		
- 90			90	58	38 - 48	81	1.4		
-105			105	73		96	1.5		
-120			120	88		111	1.6		
-135			135	103		126	1.6		
-165			165	133		156	1.8		
-200			200	168		191	2.0		
<b>-MEGA13N- 60</b> ※	2.5 - 13	35	60	32		51	51	NBC13-□	1.3
- 75※			75	45		66	66		1.4
- 90			90	60	44 - 55	81	1.5		
-105			105	73	44 - 63	96	1.6		
-120			120	90		111	1.7		
-135			135	103		126	1.8		
-165			165	133		156	2.0		
-200			200	168		191	2.2		
<b>-MEGA16N- 65</b> ※	2.5 - 16	42	65	37		56	56	NBC16-□	1.5
- 75※			75	47		66	66		1.6
- 90			90	60		48 - 57	81		1.7
-105			105	75	48 - 68	96	1.8		
-120			120	90		111	2.0		
-135			135	105		126	2.1		
-165			165	135		156	2.4		
-200			200	170		191	2.7		
<b>-MEGA20N- 65</b> ※	2.5 - 20	46	65	37		51	51	NBC20-□	1.5
- 75※			75	47		65	65		1.6
- 90			90	62		51 - 56	76		1.8
-105			105	77	51 - 68	91	2.0		
-120			120	92		104	2.1		
-135			135	107		111	2.3		
-165			165	137			2.6		
-200			200	172			2.9		

1. Nut is included. Adjusting Screw, collet and wrench must be ordered separately.

2. Weight includes the nut but not the collet.

3. Center through coolant supply is available.

4. ※ marked models cannot be used with Adjusting Screws. H dimension is the max. tool shank length that can be inserted into the holder.

5. Please note that the practical spindle speed may be considerably influenced by the machine rigidity and tool balance. When using, slowly ramp up to the appropriate speed starting from slow speeds.

Clamping diameter:  $\varnothing 0.25 - \varnothing 20$ **MEGA NEW BABY CHUCK****C8**

Model	Clamping diameter $\varnothing d$	$\varnothing D$	L	L <sub>1</sub>	H	H Max.	Collet Model	Weight (kg)
<b>C8 -MEGA 6N- 90</b>	0.25 - 6	20	90	45	23 - 43	90	NBC 6-□	2.4
<b>-120</b>			120	75		120		2.6
<b>-165</b>			165	120		165		2.7
<b>-MEGA 8N- 90</b>	0.5 - 8	25	90	46	26 - 45	90	NBC 8-□	2.6
<b>-120</b>			120	75		120		2.7
<b>-165</b>			165	120		165		2.8
<b>-MEGA10N- 90</b>	1.5 - 10	30	90	45	38 - 48	90	NBC10-□	2.7
<b>-120</b>			120	75		120		2.8
<b>-165</b>			165	120		165		3.0
<b>-MEGA13N- 90</b>	2.5 - 13	35	90	50	44 - 63	90	NBC13-□	2.8
<b>-120</b>			120	80		120		2.9
<b>-165</b>			165	120		165		3.2
<b>-200</b>			200	155		200		3.5
<b>-MEGA16N- 90</b>	2.5 - 16	42	90	50	48 - 66	90	NBC16-□	2.9
<b>-120</b>			120	80	48 - 68	120		3.2
<b>-165</b>			165	125	165	3.6		
<b>-MEGA20N- 90</b>	2.5 - 20	46	90	50	51 - 68	83	NBC20-□	3.0
<b>-120</b>			120	80		113		3.3
<b>-165</b>			165	125		113		3.8
<b>-200</b>			200	160		113		4.1

1. Nut is included. Adjusting Screw, collet and wrench must be ordered separately.

2. Weight includes the nut but not the collet.

3. Center through coolant supply is available.

4. Please note that the practical spindle speed may be considerably influenced by the machine rigidity and tool balance. When using, slowly ramp up to the appropriate speed starting from slow speeds.

Standard Accessory		Optional Accessories				
<b>MEGA NUT</b>  For Spares  <b>G12</b>	<b>O-ring</b>  For Spares  <b>G12</b>	<b>MEGA NUT Flat Type</b>   <b>G12</b>	<b>Mega Wrench</b>   <b>G33</b>	<b>Collet</b>   <b>G7</b>	<b>MEGA PERFECT SEAL</b>   <b>G13</b>	<b>Adjusting Screw</b>   <b>G23</b>

E

COLLET CHUCK

Center through

Max.  
**35,000min<sup>-1</sup>**

Collet chuck designed for endmilling.  
Powerful gripping force and substantial body design with high bending rigidity provide optimum endmilling performance.



● Model Description

**C4** - **MEGA** **6** **E** - **50**

- L dimension
- E CHUCK
- Maximum clamping diameter
- MEGA CHUCK
- Shank No.

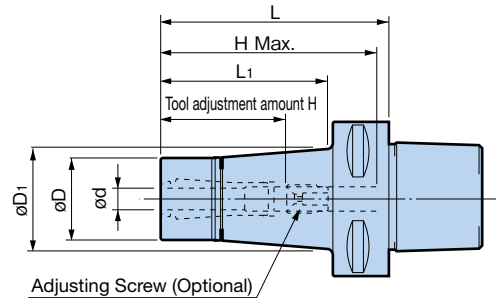

**C4/C5**

Model	Clamping diameter $\varnothing d$	$\varnothing D$	$\varnothing D_1$	L	L <sub>1</sub>	H	H Max.	Collet Model	Weight (kg)
<b>C4 -MEGA 6E- 50</b> ※	3 - 6	25	26	50	25	44	44	MEC 6-□	0.40
<b>-MEGA 8E- 50</b> ※	3 - 8	30	31	50	28	44	44	MEC 8-□	0.50
<b>-MEGA10E- 55</b> ※	3 - 10	35	37	55	34	49	49	MEC10-□	0.50
<b>-MEGA13E- 60</b> ※	3 - 12	42	—	60	—	50	50	MEC13-□	0.44
<b>C5 -MEGA 6E- 55</b> ※	3 - 6	25	26.5	55	29	37 - 45	48	MEC 6-□	0.5
<b>- 90</b>			32.5	90	64		83		0.7
<b>-105</b>			35.5	105	81		98		0.8
<b>-120</b>			38	120	97		113		0.9
<b>-MEGA 8E- 55</b> ※			31.5	55	31		48		48
<b>- 90</b>	37.5	90	67	42 - 51	83	0.8			
<b>-105</b>	40.5	105	82		98	1.0			
<b>-120</b>	43	120	98		113	1.1			
<b>-MEGA10E- 60</b> ※	37.5	60	37		53	53	MEC10-□	0.6	
<b>- 90</b>	43	90	69		48 - 58	83		0.9	
<b>-105</b>	45.5	105	84	98		1.1			
<b>-120</b>	45.5	120	99	113		1.3			
<b>-MEGA13E- 60</b> ※	44.5	60	39	50		50		MEC13-□	0.8
<b>- 75</b> ※	45	75	54	68		68	0.9		
<b>- 90</b>	45	90	69	50 - 60	83	1.1			
<b>-105</b>	46	105	84		98	1.3			
<b>-120</b>	46	120	99		113	1.4			

Refer to the remarks on the next page.

**C6/C8**

Model	Clamping diameter $\varnothing d$	$\varnothing D$	$\varnothing D_1$	L	L <sub>1</sub>	H	H Max.	Collet Model	Weight (kg)	
<b>C6 -MEGA 6E- 60</b> ※	3 - 6	25	28	60	33	51	51	MEC 6-□	1.2	
- 75			29.5	75	48	37 - 45	66		1.3	
- 90			32.5	90	63		81		1.4	
-105			35	105	78		96		1.5	
-120			37.5	120	93		111		1.6	
-135			40	135	108		126		1.8	
-165			45.5	165	138		156		2.1	
<b>-MEGA 8E- 60</b> ※			3 - 8	30	33		60		33	51
- 75	34.5	75			48		42 - 46	66	1.4	
- 90	37	90			63	42 - 51	81	1.5		
-105	39.5	105			78		96	1.7		
-120	42.5	120			93		111	1.8		
-135	45	135			108		126	1.9		
-165	50.5	165			140		156	2.4		
<b>-MEGA10E- 65</b> ※	3 - 10	35			38.5		65	38	56	56
- 75			39.5	75	48		66	66	1.5	
- 90			42	90	63		48 - 58	81	1.6	
-105			44.5	105	78	96		1.8		
-120			47	120	93	111		2.0		
-135			50	135	110	126		2.2		
-165			55.5	165	141	156		2.7		
<b>-MEGA13E- 65</b> ※			3 - 12	42	45.5	65		39	56	56
- 75	46	75			49	66		66	1.6	
- 90	49	90			66	50 - 55		81	1.8	
-105	51.5	105			80		96	2.1		
-120	54.5	120			96		111	2.3		
-135	57	135			112		126	2.6		
-165	62.5	165			141		156	3.2		
<b>C8 -MEGA 6E- 90</b>	3 - 6	25			31		90	55	37 - 45	90
-135			38.5	135	100		135	3.0		
<b>-MEGA 8E- 90</b>	3 - 8	30	35.5	90	55		42 - 51	90	MEC 8-□	2.7
-135			43.5	135	100	135		3.2		
<b>-MEGA10E- 90</b>	3 - 10	35	40.5	90	55	48 - 58	90	MEC10-□	2.8	
-120			46	120	85		120		3.2	
-135			48.5	135	100		135		3.4	
<b>-MEGA13E- 90</b>	3 - 12	42	47	90	55	50 - 60	90	MEC13-□	3.0	
-120			52.5	120	85		120		3.4	
-135			55	135	100		135		3.7	
-165			60.5	165	130		165		4.3	

1. Nut is included. Adjusting Screw, collet and wrench must be ordered separately.

2. Weight includes the nut but not the collet.

3. Center through coolant supply is available.

4. ※ marked models cannot be used with Adjusting Screws. H dimension is the max. tool shank length that can be inserted into the holder.

5. Please note that the practical spindle speed may be considerably influenced by the machine rigidity and tool balance. When using, slowly ramp up to the appropriate speed starting from slow speeds.

Standard Accessory		Optional Accessories			
<b>MEGA E Nut</b>  For Spares 	<b>O-ring</b>  For Spares 	<b>Mega Wrench</b>  	<b>MEGA E Collet</b>  	<b>MEGA E PERFECT SEAL</b>  	<b>Adjusting Screw</b>  

Note that suitable Mega Wrench models differ between the Mega E Chuck and Mega New Baby Chuck even for the same body size series, i.e. MEGA6E and MEGA6N require different wrenches from each other.

High-precision collet chuck system with a 1 micron runout accuracy at nose.  
Applicable to various machining needs as a reliable general-purpose holder.

Center through



● Model Description

**C6** - **NBS** **6** - **75**

- L dimension
- Maximum clamping diameter
- NEW BABY CHUCK
- Shank No.

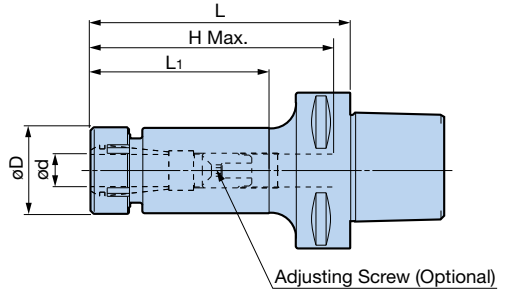

**C6**

Model	Clamping diameter $\varnothing d$	$\varnothing D$	L	L <sub>1</sub>	H Max.	Collet Model	Weight (kg)
<b>C6-NBS 6- 75</b>	0.25 - 6	20	75	43	66	NBC 6-□	0.9
-105			105	73	96		1.0
-135			135	103	126		1.0
-165			165	133	156		1.0
-200			200	168	191		1.1
<b>-NBS 8- 75</b>	0.5 - 8	25	75	43	66	NBC 8-□	1.0
-105			105	73	96		1.0
-135			135	103	126		1.1
-165			165	133	156		1.2
-200			200	168	191		1.3
<b>-NBS10- 75</b>	1.5 - 10	30	75	43	66	NBC10-□	1.0
-105			105	73	96		1.1
-135			135	103	126		1.3
-165			165	133	156		1.4
-200			200	168	191		1.6
<b>-NBS13- 75</b>	2.5 - 13	35	75	45	66	NBC13-□	1.1
-105			105	73	96		1.2
-135			135	103	126		1.4
-165			165	133	156		1.6
-200			200	168	191		1.8
<b>-NBS16- 75*</b>	2.5 - 16	42	75	47	66	NBC16-□	1.2
-105			105	75	96		1.4
-135			135	105	108		1.7
-165			165	135	108		2.0
-200			200	170	108		2.3
<b>-NBS20- 75*</b>	2.5 - 20	46	75	47	65	NBC20-□	1.2
-105			105	77	88		1.5
-135			135	107	108		1.8
-165			165	137	108		2.2
-200			200	172	108		2.6

1. Nut is included. Adjusting Screw, collet and wrench must be ordered separately.
2. Center through coolant supply is available.
3. Models marked with \* cannot be used with Adjusting Screws. H dimension is the max. tool shank length that can be inserted into the holder.

Standard Accessory	Optional Accessories				
<p>New Baby Nut</p> <p>For Spares <b>G15</b></p>	<p>New Baby Wrench</p> <p><b>G36</b></p>	<p>Collet</p> <p><b>G7</b></p>	<p>BABY PERFECT SEAL</p> <p><b>G15</b></p>	<p>Adjusting Screw</p> <p><b>G23</b></p>	<p>Tap Adjusting Screw</p> <p><b>G23</b></p>

COLLET CHUCK

E

Clamping diameter:  $\varnothing 12 - \varnothing 32$ **MEGA DOUBLE POWER CHUCK**

Complete contact with the nut and body.  
High rigidity holder for large endmills equal  
to integration with the machine spindle.

**[Jet Through Type]**

Center through

Coolant to tool periphery

Max.  
30,000min<sup>-1</sup>

## ● Model Description

C4 - MEGA 16 DS - 70

● DOUBLE POWER CHUCK  
Jet Through Type

● Clamping diameter

● MEGA CHUCK

● Shank No.

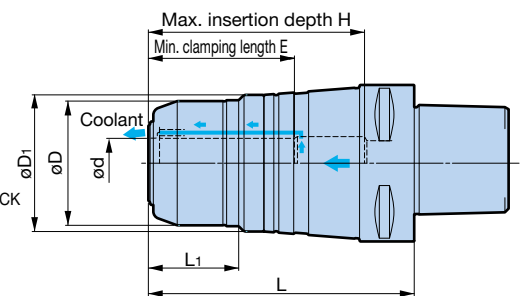
**C4/C5/C6/C8**

Model	Clamping diameter $\varnothing d$	$\varnothing D$	$\varnothing D_1$	L	L <sub>1</sub>	H	E	Mega Wrench Model	Weight (kg)
C4 - MEGA16DS- 70	16	46	47	70	26	64	48	MGR46L	0.73
-MEGA20DS- 65	20	50	51	65	31	59	50	MGR50L	0.70
C5 - MEGA16DS- 65A	16	42	53	66	26	59	48	MGR42L	0.8
- 90A				91		72			1.3
-MEGA20DS- 75A	20	50	55	76	35	69	50	MGR50L	1.1
- 90A				91		84			1.4
-MEGA25DS- 75A※	25	62	63	76	40	69	56	MGR62L	1.4
- 90A				91		84			1.7
C6 - MEGA12DS- 90 <b>NEW</b>	12	38	43	91	25	82	43	MGR38	1.4
-MEGA16DS- 70A				71		62			1.6
- 90A				91		82			2.0
-105A○				106		72			2.3
-135A○	16	42	53	136	26	72	48	MGR42L	2.9
-MEGA20DS- 75A				76		67			1.9
- 90A				91		82			2.1
-105A				106		86			2.4
-135A△	20	50	55	136	35	70 - 80	50	MGR50L	3.0
-MEGA25DS- 75A※				76		67			2.1
- 90A				91		82			2.4
-105A				106		86			2.8
-135A△	25	62	63	136	40	72 - 82	56	MGR62L	3.3
-MEGA32DS- 90A				91		82			2.5
-105A				106		91			2.9
-135A△				136		80 - 90			3.4
C8 - MEGA16DS- 70	16	46	55	71.5	25	72	48	MGR46L	2.8
-105 ○				106.5					3.6
-135 ○				136.5					4.1
-MEGA20DS- 75	20	60	69	76.5	27	76	50	MGR60L	3.3
-135 △				136.5		5.0			
-165 △				166.5		5.9			
-MEGA25DS- 75	25	70	77	76.5	33	76	56	MGR70L	3.4
-135 △				136.5		5.4			
-165 △				166.5		6.4			
-MEGA32DS- 90	32	80	86	91.5	41	91	60	MGR80L	4.3
-105				106.5		4.8			
-135				136.5		6.0			
-165 △				166.5		7.3			

- Wrench must be ordered separately.
- Jet-through type provides coolant from the chuck nose, thus tools with oil holes cannot be used.
- Models marked with △ can be used with optional axial adjusting screws. Models marked with ○ require the hex socket head screw (M8) for axial adjustment. However, please contact us if using for center through applications. **Adjusting screws cannot be used with models without the symbols above.**
- H dimension is the max. tool shank length that can be inserted into the holder. Models marked with △ show the adjustment amount when using an optional axial adjusting screw.
- Please note that the practical spindle speed may be considerably influenced by the machine rigidity and tool balance. When using, slowly ramp up to the appropriate speed starting from slow speeds.

**Optional Accessories**

## STRAIGHT COLLET



PJC Collet **G25**  
PSC Collet **G26**  
C Collet **G28**

## Mega Wrench

**G33**

## Axial Adjusting Screw

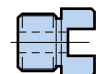
**G30**

- ※ marked models are not compatible with some Straight Collets. Compatibility Table **G24**





The BIG original slit mechanism supports high power and high-precision endmilling from heavy cuts to fine cuts.



● Model Description  
**C5** - **HMC** **16** **S** - **65**  
 ● Shank No.  
 ● S Type  
 ● Chuck bore  
 ● NEW Hi-POWER MILLING CHUCK  
 ● L dimension

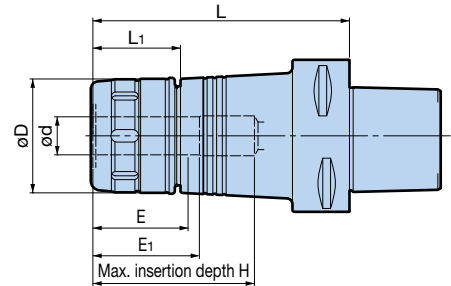





**C5/C6/C8**

Model	Clamping diameter $\phi d$	$\phi D$	L	L <sub>1</sub>	H	Min. clamping length		FK Wrench Model	MEGA WRENCH Model	Weight (kg)
						E	E <sub>1</sub>			
<b>C5-HMC16S- 65</b>	16	43	65	44	58	48	55	FK45-50L	MGR43L	0.8
<b>-HMC20S- 75</b>	20	50	75	44	68	50	56		MGR50L	1.0
<b>-105</b>			105						85	1.4
<b>-HMC25S- 75</b> ※	25	55	75	47	68	56	57	FK52-55	MGR55L	1.3
<b>-105</b>			105						87	1.7
<b>-HMC32S- 85</b> ※	32	62	85	56	78	60	58	FK58-62L	MGR62L	1.6
<b>C6-HMC16S- 70</b>	16	43	70	44	61	48	55	FK45-50L	MGR43L	1.5
<b>-HMC20S- 75</b>	20	50	75	44	66	50	56		MGR50L	1.7
<b>-105</b>			105						85	2.3
<b>-120</b> △			120		69 - 79				2.5	
<b>-HMC25S- 75</b> ※	25	59	75	45	66	56	57	FK58-62L	MGR59L	2.0
<b>-105</b>			105							87
<b>-135</b> △			135		73 - 83				3.1	
<b>-HMC32S- 90</b>	32	68	90	54	81	60	64	FK68-75L	MGR68L	2.4
<b>-105</b>			105		90					2.7
<b>-135</b> △			135		79 - 89					3.3
<b>C8-HMC20- 80</b>	20	60	80	46	80	50	56	FK58-62	MGR60L	3.3
<b>-135</b> △			135		69 - 79				4.7	
<b>-HMC25- 85</b>	25	62	85	55	85	56	65		MGR62L	3.5
<b>-135</b> △			135		76 - 86			4.7		
<b>-HMC32- 95</b>	32	80	95	63	95	60	71	FK80-90	MGR80L	4.5
<b>-135</b>			135		105					5.8

1. Wrench must be ordered separately.
2. Models with △ indication can be used with optional axial adjusting screws.  
**Adjusting screws cannot be used with models without the symbols above.**
3. H dimension is the max. tool shank length that can be inserted into the holder.  
 △ marked models show the adjustment amount when using an optional axial adjusting screw.
4. When using center through coolant, insert a tool shank into E<sub>1</sub> or more.

- ※ marked models are not compatible with some Straight Collets. Compatibility Table [G24](#)
- MEGA WRENCH can also be used to tighten/remove tools.

**Optional Accessories**

Straight Collet	Wrench	Mega Wrench	Axial Adjusting Screw
 PJC Collet <a href="#">G25</a> PSC Collet <a href="#">G26</a> OCA Collet <a href="#">G27</a> C Collet <a href="#">G28</a>	 <a href="#">G30</a>	 <a href="#">G33</a>	 <a href="#">G30</a>

E  
MILLING CHUCK



Secure chucking with just one wrench. Ideal for various high precision machining requirements.

Center through

[Super slim Type]

Runout accuracy 4D  
**3 $\mu$ m** or less



● Model Description  
**C4** - **HDC** **3** **S** - **55**  
 ● L dimension  
 ● Super slim Type  
 ● Clamping diameter  
 ● HYDRAULIC CHUCK  
 ● Shank No.

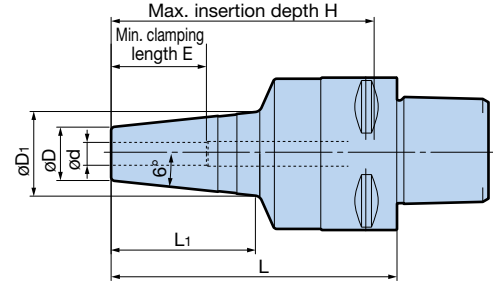

## C4

Model	Clamping diameter $\phi d$	$\phi D$	$\phi D_1$	L	L <sub>1</sub>	E	H	Weight (kg)
<b>C4-HDC 3S- 55</b> <small>NEW</small>	3	14	18	55	17	16	49	0.38
<b>-HDC 4S- 75</b> <small>NEW</small>	4		23			19		0.43
<b>-HDC 6S- 75</b> <small>NEW</small>	6	26	38		25	0.42		
<b>-HDC 8S- 75</b> <small>NEW</small>	8				31	0.45		
<b>-HDC10S- 75</b> <small>NEW</small>	10	19	28		39	33		0.45
<b>-HDC12S- 75</b> <small>NEW</small>	12	21	30			36		0.46

- Adjusting Screw cannot be used.
- It is recommended to use a Grip Bar to periodically confirm the gripping force of the Hydraulic Chuck. **G30**

### Caution

- Use only cutting tools that have a shank tolerance within h6.
- Do not use with cutting tools made with a flat on the shank. (ie: Weldon type shank)
- We do not recommend use with roughing endmills.
- Do not clamp without a tool.
- Always insert the cutting tool into the holder beyond min. clamping length E.

E  
HYDRAULIC CHUCK

Center through

[Jet Through Type PAT.]



Runout accuracy 4D  
**3 $\mu$ m** or less

● Model Description  
**C5** - **HDC** **4** **J** - **90**  
 ● L dimension  
 ● Jet Through Type  
 ● Clamping diameter  
 ● HYDRAULIC CHUCK  
 ● Shank No.

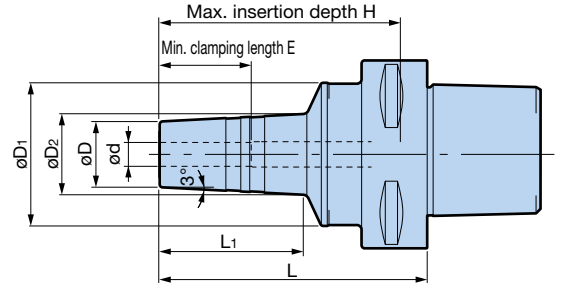

## C5/C6

Model	Clamping diameter ød	øD	øD <sub>1</sub>	øD <sub>2</sub>	L	L <sub>1</sub>	H	E	Weight (kg)
<b>C5-HDC 4J- 90</b>	4	20	42	26	90	51	83	19	0.72
<b>-HDC 6J- 90</b>	6			28				25	0.71
<b>-HDC 8J- 90</b>	8			30				31	0.72
<b>-HDC10J- 90</b>	10			32				33	0.75
<b>-HDC12J- 90</b>	12			34				36	0.78
<b>C6-HDC 4J- 90</b>	4	20	48	26	90	47	81	19	1.1
<b>-HDC 6J- 90</b>	6			28	25	1.1			
<b>-120</b>	120			74	111	1.3			
<b>-HDC 8J- 90</b>	8			30	31	1.1			
<b>-120</b>	120			75	111	1.3			
<b>-HDC10J- 90</b>	10			32	33	1.1			
<b>-120</b>	120			75	111	1.3			
<b>-HDC12J- 90</b>	12			34	36	1.2			
<b>-120</b>	120			76	111	1.3			

- Adjusting Screw cannot be used.
  - HDC4J to 12J models allow jet through to be switched to center through by assembling the accessory plug.
- It is recommended to use a Grip Bar to periodically confirm the gripping force of the Hydraulic Chuck. **G30**

### Caution

- Use only cutting tools that have a shank tolerance within h6.
- Do not use with cutting tools made with a flat on the shank. (ie: Weldon type shank)
- We do not recommend use with roughing endmills.
- Do not clamp without a tool.
- Always insert the cutting tool into the holder beyond min. clamping length E.

E  
HYDRAULIC CHUCK

Center through

**[Standard Type]**Runout accuracy 4D  
**3 $\mu$ m** or less

## ● Model Description

**C5** - **HDC** **14** - **90**  
 ● L dimension  
 ● Clamping diameter  
 ● HYDRAULIC CHUCK  
 ● Shank No.

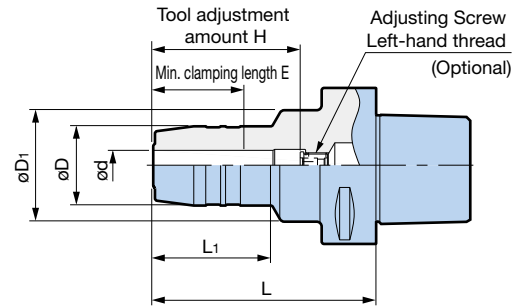
**C5/C6**

Model	Clamping diameter $\phi d$	$\phi D$	$\phi D_1$	L	L <sub>1</sub>	H	E	Adjusting Screw (Optional)	Weight (kg)
<b>C5-HDC14- 90</b>	14	34	45	90	48	53 - 60	38	HDA12-10010○	1.1
<b>-HDC16- 75</b> ※	16	38	50	75	35	68	43	—	1.1
<b>- 90</b> ※			48	90	48	83		—	1.2
<b>-HDC18- 90</b> ※	18	40	48	90	48	83	43	—	1.2
<b>-HDC20- 75</b> ※	20	42	52	75	35	68	43	—	1.1
<b>- 90</b> ※			50	90	48	83		—	1.2
<b>-HDC25- 90</b> ※	25	55	63	90	48	83	52	—	1.7
<b>C6-HDC14- 90</b>	14	34	45	90	48	48 - 60	38	HDA10-08015	1.6
<b>-120</b>			120	—	38 - 60	HDA10-08032		1.9	
<b>-HDC16- 75</b> ※	16	38	50	75	35	66	43	—	1.6
<b>- 90</b> ※			47	90	48	81		—	1.7
<b>-120</b>	18	40	48	120	48	43 - 70	43	HDA16-12037	2.0
<b>-HDC18- 90</b> ※			48	90	48	66		—	1.7
<b>-120</b>	20	42	49	120	48	43 - 70	43	HDA16-12037	2.0
<b>-HDC20- 75</b> ※			53	75	33	66		—	1.7
<b>- 90</b> ※	20	42	50	90	48	72	43	—	1.8
<b>-120</b>			50	120	48	43 - 70		HDA16-12037	2.1
<b>-HDC25- 90</b> ※	25	55	63	90	46	80	52	—	2.2
<b>-120</b>			63	120	51	67 - 79		HDA20-16015	2.8
<b>-HDC32- 90</b> ※	32	75	63	90	43	81	56	—	2.8
<b>-120</b>		63	—	120	—	66 - 78		HDA20-16015	3.0

- Tool adjustment amount "H" indicates the adjustment length with an Adjusting Screw.
  - Models marked with ※ cannot be used with Adjusting Screws. H dimension is the max. tool shank length that can be inserted into the holder.
  - Adjusting Screw with hexagon sockets on both sides is also available, allowing adjustment from the shank side as well.  
Add the letter "W" at the end of the model number when ordering. (Example: **HDA10-0815W**)
  - The above type is not available for the **HDA12-10010** marked with ○.
- It is recommended to use a Grip Bar to periodically confirm the gripping force of the Hydraulic Chuck. **G30**

**Caution**

- Use only cutting tools that have a shank tolerance within h6.
- Do not use with cutting tools made with a flat on the shank. (ie: Weldon type shank)
- We do not recommend use with roughing endmills.
- Do not clamp without a tool.
- Always insert the cutting tool into the holder beyond min. clamping length E.

Holder material  
Tool steel

Center through

[Slim Type]

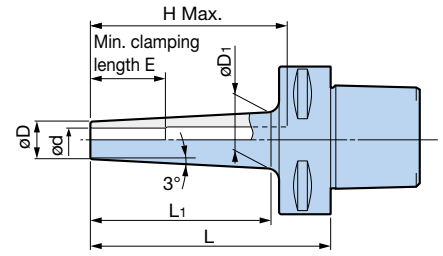
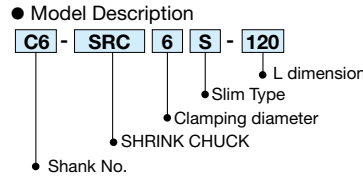

**C6**

Model	Clamping diameter $\phi d$	$\phi D$	$\phi D_1$	L	L <sub>1</sub>	E	H Max.	Weight (kg)
<b>C6-SRC 6S-120</b>	6	10	19.5	120	92	26	111	1.2
<b>-165</b>			24	165	133		156	1.4
<b>-SRC 8S-120</b>	8	13	22.5	120	92	26	111	1.3
<b>-165</b>			27	165	133		156	1.5
<b>-SRC10S-120</b>	10	16	25.5	120	92	32	111	1.3
<b>-165</b>			30.5	165	135		156	1.5
<b>-SRC12S-120</b>	12	19	28.5	120	92	36	111	1.4
<b>-165</b>			33	165	135		156	1.6

1. Use a carbide shank cutter within a tolerance of h6. HSS tools cannot be used.

<Some shrink fit machines may not be compatible with the Shrink Chuck. Please refer to the shrink fit machine operation manual.>

[Standard Type]

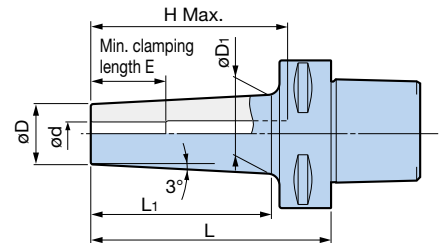
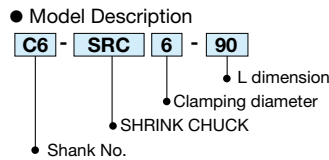

**C6**

Model	Clamping diameter $\phi d$	$\phi D$	$\phi D_1$	L	L <sub>1</sub>	E	H Max.	Weight (kg)
<b>C6-SRC 6- 90</b>	6	14	20.5	90	63	26	81	1.2
<b>-SRC 8- 90</b>	8	18	24.5	90	63	26		1.3
<b>-SRC10- 90</b>	10	22	28.5	90	63	32		1.3
<b>-SRC12- 90</b>	12	24	30.5	90	63	36		1.4
<b>-SRC16- 90</b>	16	28	34.5	90	63	38	80	1.4
<b>-165</b>			42.5	165	138			2.1
<b>-SRC20- 90</b>	20	34	40.5	90	63	42	80	1.5
<b>-165</b>			48.5	165	138			100

1. Use a carbide shank cutter within a tolerance of h6. HSS tools cannot be used.

<Some shrink fit machines may not be compatible with the Shrink Chuck. Please refer to the shrink fit machine operation manual.>

SHRINK CHUCK

Center through

CK SHANK

● Basic holder for rough and finish boring heads of the proven **BIG** +KAISER Boring System.



C4/C5/C6/C8

Model	CK No.	øD	L	A	Weight (kg)
<b>C4-CKB1- 48</b>	CK1	19	47.5	22	0.30
<b>-CKB2- 45</b>	CK2	24	44.5	19	0.31
<b>-CKB3- 40</b>	CK3	31	40	17	0.32
<b>-CKB4- 33</b>	CK4	39	33	15	0.29
<b>C5-CKB1- 73</b>	CK1	19	72.5	47	0.5
<b>-CKB2- 85</b>	CK2	24	84.5	60	0.6
<b>-CKB3- 55</b>	CK3	31	55	30	0.6
<b>-CKB4- 48</b>	CK4	39	48	24	0.6
<b>-CKB5- 50</b>	CK5	50	50	(30)	0.6
<b>-CKB6- 50</b>	CK6	64	50	(30)	1.0
<b>C6-CKB1- 78</b>	CK1	19	77.5	50	1.2
<b>-CKB2- 90</b>	CK2	24	89.5	62	1.3
<b>-CKB3- 65</b>	CK3	31	65	38	1.3
<b>-100</b>			100	73	1.5
<b>-CKB4- 58</b>	CK4	39	58	31	1.3
<b>- 93</b>			93	66	1.7
<b>-CKB5- 48</b>	CK5	50	48	22	1.3
<b>- 83</b>			83	57	1.7
<b>-CKB6- 59</b>	CK6	64	59	(37)	1.6
<b>- 94</b>			94	(72)	2.3
<b>C8-CKB4-118</b>	CK4	39	118	83	2.4
<b>-178</b>			178	143	3.0
<b>-CKB5-108</b>	CK5	50	108	73	2.7
<b>-183</b>			183	148	3.8
<b>-CKB6- 74</b>	CK6	64	74	39	2.5
<b>-169</b>			169	135	4.8
<b>-CKB7- 73</b>	CK7	90	73	(43)	3.1
<b>-123</b>			123	(93)	5.6

● Model Description  
**C4** - **CKB1** - **48**  
 ● CK No. ● L dimension  
 ● Shank No.

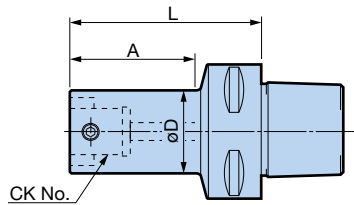

1. Center through coolant supply is available.

Heads **A41**

E  
 CK BORING SYSTEM

## SYNCHRONIZED TAP HOLDER STC Type M2 - M30

- Tap Collet type enables quick tap change.
- Flexible tool layout in combination with the CK Shanks.

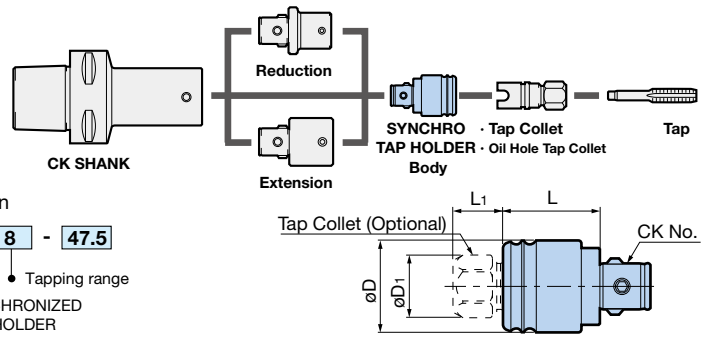

● Model Description  
**CKB2** - **STC** **8** - **47.5**  
 ● CK No. ● TAPPING RANGE  
 ● SYNCHRONIZED TAP HOLDER

Model	Tapping capacity	CK No.	øD	øD <sub>1</sub>	L	L <sub>1</sub>	Body weight (kg)	Tap Collet
<b>CKB2-STC 8-47.5</b>	M 2 - M 4	CK2	25.5	15.8	30.5	17	0.10	TC 8-□
	M 5 - M 8			19				
<b>CKB3-STC12-66</b>	M 3 - M12	CK3	32	22	36	30	0.18	TC12-□
<b>CKB4-STC20-72</b>	M 7 - M12	CK4	44	22	47	25	0.42	TC20-□
	M14 - M20			31				
<b>CKB5-STC30-92</b>	M20 - M30	CK5	55	41	54	38	0.72	TC30-□

1. Tap collet must be ordered separately.
2. Cannot be used with machining center without synchronized tapping function.
3. The L<sub>1</sub> dimension is 5mm longer with oil hole tap collets.

👉 Holders **E52**

### Tap Collet TC Type (optional accessory)



👉 Tap Collets **A144**

👉 Oil Hole Tap Collet **A145**

## CK AUTO TAPPER E Type M3 - M24

- Axial float function and built-in torque limiter.
- Convenient for combination with CK shanks.

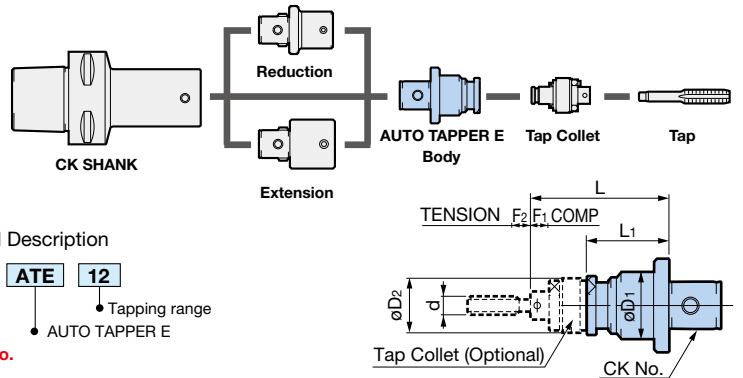

● Model Description  
**CK6** - **ATE** **12**  
 ● CK No. ● TAPPING RANGE  
 ● AUTO TAPPER E

Model	Tapping range	CK No.	øD <sub>1</sub>	øD <sub>2</sub>	L	L <sub>1</sub>	F <sub>1</sub>	F <sub>2</sub>	Weight (kg)	Tap Collet
<b>CK6-ATE12</b>	M3 - M12	CK6	47	38.5	90	50	5	10	0.9	TCE12-□
<b>-ATE24</b>	M9 - M24		64	58.5	135	80	7	15	1.8	TCE24-□

1. Torque limiter is built into the tap collet.
2. The extension can be used to allow tapping inside deep holes.
3. Tap collet must be ordered separately.

👉 Holders **E52**

### Tap Collet TCE Type (optional accessory)



👉 Tap Collets **A147**

Center through

Absorbs and corrects machine synchronization errors for improved tap life.

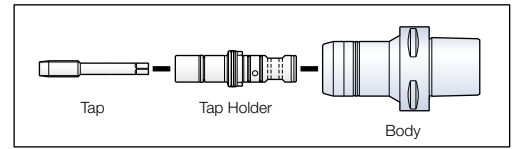

- Model Description
- C5** - **MGT6** - **75**
- L dimension
- MEGA SYNCHRO No.
- Shank No.

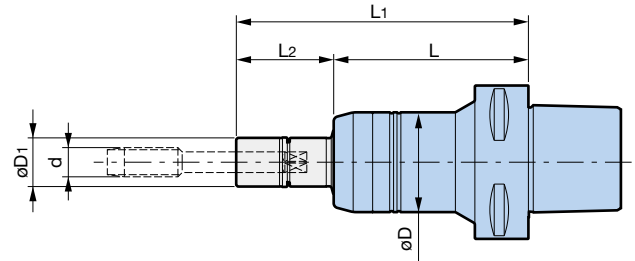

## C5/C6/C8

Model	Tap Holder Model	Tapping range $d$	$\phi D$	$\phi D_1$	L	$L_1$	$L_2$	Weight (kg)
<b>C5-MGT 6- 75</b>	MGT 6-□- 30	M2 - M6 No.3 - U1/4	36	16	75	105	30	0.8
	- 70					145	70	
	-100					175	100	
<b>-MGT12- 75</b>	MGT12-□- 30	M6 - M12 U1/4 - U7/16 P1/8	41	20	75	105	30	0.9
	- 70					145	70	
	-100					175	100	
<b>-MGT20-100</b>	MGT20-□- 35	M12 - M20 U1/2 - U3/4 P1/4 - P3/8	54	30	100	135	35	1.4
	- 85					185	85	
	-115					215	115	
<b>C6-MGT 6- 80</b>	MGT 6-□- 30	M2 - M6 No.3 - U1/4	36	16	80	110	30	1.1
	- 70					150	70	
	-100					180	100	
<b>-MGT12- 80</b>	MGT12-□- 30	M6 - M12 U1/4 - U7/16 P1/8	41	20	80	110	30	1.2
	- 70					150	70	
	-100					180	100	
<b>-MGT20-100</b>	MGT20-□- 35	M12 - M20 U1/2 - U3/4 P1/4 - P3/8	54	30	100	135	35	1.8
	- 85					185	85	
	-115					215	115	
<b>C8-MGT 6- 80</b>	MGT 6-□- 30	M2 - M6 No.3 - U1/4	36	16	80	110	30	2.1
	- 70					150	70	
	-100					180	100	
<b>-MGT12- 80</b>	MGT12-□- 30	M6 - M12 U1/4 - U7/16 P1/8	41	20	80	110	30	2.2
	- 70					150	70	
	-100					180	100	
<b>-MGT20- 95</b>	MGT20-□- 35	M12 - M20 U1/2 - U3/4 P1/4 - P3/8	54	30	95	130	35	2.6
	- 85					180	85	
	-115					210	115	

1. MGT Set Screw is included.

2. Tap holder is not included. Please order separately.

Cannot be used with machining center without synchronized tapping function.

$L_2=150, 200$ mm tap holders are also available. For details, see **A134 - A135**

Tap holders **A134**

Accessories **G31**



Face mill arbor capable of securely supplying coolant/air to cutting edges through oil holes of cutters.

**Securely supplies coolant/air to the cutting edge.**

**What is FMH?**  
New standard of the arbors with coolant holes, which major Japanese carbide insert manufacturers established jointly, ideal for the high efficiency radius milling cutters and plunge milling cutters.



● Model Description  
**C4** - **FMH** **22** - **47** - **45**  
 ● L dimension  
 ●  $\phi D_1$  dimension  
 ● Spigot diameter  
 ● FACE MILL ARBOR TYPE H  
 ● Shank No.

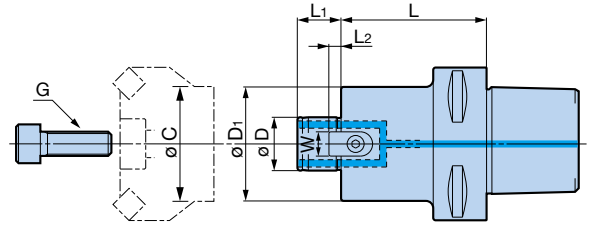

### C4/C5/C6/C8

Model	$\phi D$ (h6)	$\phi D_1$	L	L <sub>1</sub>	Drive Key		G	Weight (kg)	Minimum flange diameter $\phi C$
					L <sub>2</sub>	W			
<b>C4-FMH22- 47- 45</b> <small>NEW</small>	22	47	45	18	5	10	M10	0.62	38
<b>C5-FMH22- 47- 60</b>	22	47	60	18	5	10	M10	1.2	36
- 90			90					1.6	
<b>-FMH22- 60- 60</b>			60					1.4	
<b>-FMH27- 60- 60</b>	27	60	60	20	6	12	M12	1.5	46
<b>C6-FMH22- 47- 45</b>	22	47	45	18	5	10	M10	1.5	38
- 60			60					1.8	
- 90			90					2.2	
-150			150					3.0	
<b>-FMH22- 60- 45</b>			45					1.8	
- 60	22	60	60	18	5	10	M10	2.1	38
- 90			90					2.8	
<b>-FMH27- 60- 45</b>			45					1.9	
- 60	27	60	60	20	6	12	M12	2.2	46
- 90			90					2.8	
-150			150					4.2	
<b>C8-FMH22- 47- 60</b>	22	47	60	18	5	10	M10	2.9	36
-105			105					3.5	
-150			150					4.1	
-200			200					4.8	
<b>-FMH22- 60- 60</b>			60					3.2	
-105	22	60	105	18	5	10	M10	4.2	38
-150			150					5.2	
<b>-FMH27- 60- 60</b>			60					3.3	
-105	27	60	105	20	6	12	M12	4.3	46
-150			150					5.3	
-200			200					6.4	
<b>-FMH32- 96- 75</b>	32	96	75	22	7	14	M16	4.9	58
-105			105					6.1	
-150			150					7.8	

1. Cutter clamp screw (hex socket head screw) is included. If the cutter requires a clamping bolt with larger clamping head diameter, please order the suitable model from the table below.

### Clamping Screws

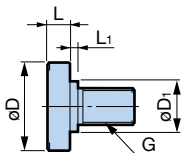

Model	$\phi D$	$\phi D_1$	L	L <sub>1</sub>	G
<b>MBA-M12</b>	33	23	10	2	12
<b>-M12H</b>		—		—	
<b>-M16</b>	40	23	10	6	16
<b>-M16H</b>		—		—	



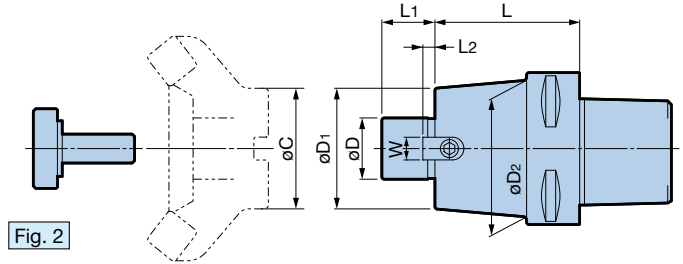
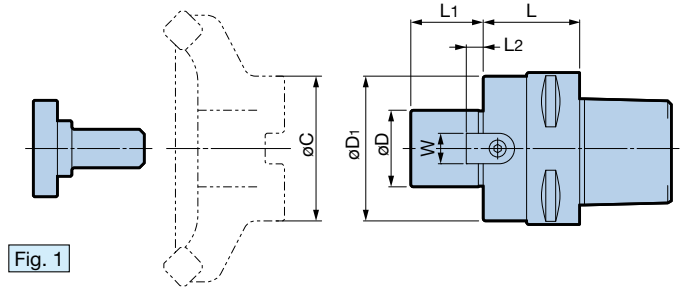

● Model Description  
**C4** - **FMA** **25.4** - **40**  
 ● L dimension  
 ● Spigot diameter  
 ● FACE MILL ARBOR TYPE A  
 ● Shank No.

**C4/C5/C6/C8**

Model	Fig.	øD (h6)	øD <sub>1</sub>	øD <sub>2</sub>	L	L <sub>1</sub>	Drive Key		Clamping Screw	Weight (kg)	Minimum flange diameter øC
							L <sub>2</sub>	W			
<b>C4-FMA25.4 - 40</b>	1	25.4	50	—	40	22	5	9.5	MBA-M12	0.7	36
<b>C5-FMA25.4 - 40</b>	1	25.4	50	—	40	22	5	9.5	MBA-M12	0.9	36
<b>- 75</b>					75					1.2	
<b>C6-FMA25.4 - 40</b>	2	25.4	50	54	40	22	5	9.5	MBA-M12	1.4	36
<b>- 60</b>				57	60					1.8	
<b>- 90</b>				60	90					2.4	
<b>-FMA31.75- 40</b>	1	31.75	60	—	40	30	7	12.7	MBA-M16	1.6	47
<b>- 90</b>					90					2.6	
<b>-FMA38.1 - 45</b>	1	38.1	80	—	45	34	9	15.9	MBA-M20	2.2	75
<b>C8-FMA25.4 - 40</b>	2	25.4	50	53	40	22	5	9.5	MBA-M12	2.7	36
<b>- 75</b>				60	75					3.2	
<b>-105</b>				105	3.8						
<b>-FMA31.75- 40</b>				62	40					2.7	
<b>- 90</b>	70	90	4.0								
<b>-FMA38.1 - 45</b>	1	38.1	80	—	45	34	9	15.9	MBA-M20	3.2	70

1. Cutter clamp screw is included.
2. Depending on the cutter, a hex socket head screw may be required for clamping.
3. A clamp screw with oil hole must be ordered separately for use with center through coolant/air.

■ Clamping screw with oil hole

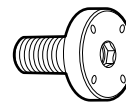

Model
<b>TMBA-M12</b>
<b>-M16</b>
<b>-M20</b>

● Model Description  
**C6** - **FMC** **16** - **40**  
 ● L dimension  
 ● Spigot diameter  
 ● FACE MILL ARBOR TYPE C  
 ● Shank No.

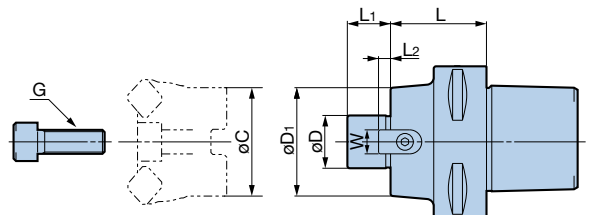

**C6**

Model	øD	øD <sub>1</sub>	L	L <sub>1</sub>	Drive Key		G	Weight (kg)	Minimum flange diameter øC
					L <sub>2</sub>	W			
<b>C6-FMC16-40</b>	16	32	40	16	5	8	M 8	1.3	28
<b>-FMC22-40</b>	22	45	40	18	5	10	M10	1.4	34

1. Cutter clamp screw is included.

# SIDE LOCK ENDMILL HOLDER

Center through



● Model Description  
**C6** - **ISL** **16** - **80**  
 ● L dimension  
 ● Clamping diameter  
 ● SIDE LOCK ENDMILL HOLDER  
 ● Shank No.

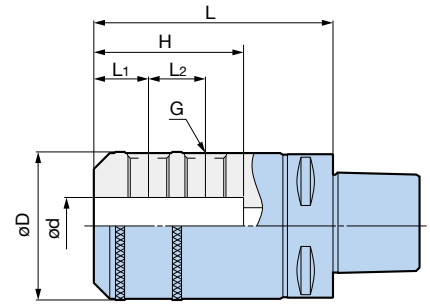

**C6** Endmill holder in accordance with ISO5414

Model	ød	øD	L	L <sub>1</sub>	L <sub>2</sub>	H	G	Weight (kg)
<b>C6-ISL16- 80</b>	16	48	80	24	—	52	M14	1.8
<b>-ISL20- 80</b>	20	52	80	25		55	M16	1.9
<b>-ISL25-105</b>	25	65	105	24	25	60	M18 P2.0	2.9
<b>-ISL32-115</b>	32	72	115	24	28	90	M20 P2.0	3.5

1. Center through coolant supply is available.

E

GENERAL TOOLHOLDER

# JACOBS TAPER ARBOR



● Model Description  
**C5** - **JTA** **6** - **40**  
 ● L dimension  
 ● JT No.  
 ● JACOBS TAPER ARBOR  
 ● Shank No.

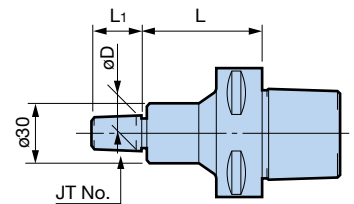

**C5/C6/C8**

Model	JT No.	øD	L	L <sub>1</sub>	Weight (kg)
<b>C5-JTA6-40</b>	6	17.17	40	24	0.5
<b>C6-JTA6-40</b>	6	17.17	40	24	1.2
<b>C8-JTA6-50</b>	6	17.17	50	24	2.5

1. The model, dimensions and accuracy conform to TMT standards.

# GENERAL TOOLHOLDER MORSE TAPER HOLDER TYPE A

**BIG**  
CAPTO  
SHANK



● Model Description

**C5** - **MTA** **1** - **95**

- L dimension
- MT No.
- MORSE TAPER HOLDER TYPE A
- Shank No.

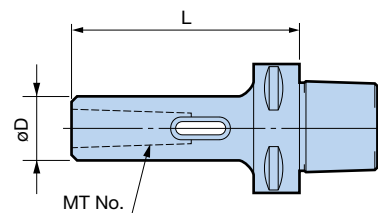

## C5/C6/C8

Model	MT No.	øD	L	Weight (kg)
<b>C5-MTA1- 95</b>	1	25	95	0.6
<b>-MTA2-110</b>	2	32	110	0.8
<b>-MTA3-130</b>	3	40	130	1.2
<b>C6-MTA1- 95</b>	1	25	95	1.3
<b>-MTA2-110</b>	2	32	110	1.5
<b>-MTA3-130</b>	3	40	130	1.9
<b>C8-MTA1-105</b>	1	25	105	2.6
<b>-MTA2-120</b>	2	32	120	2.8
<b>-MTA3-140</b>	3	40	140	3.2

1. The model, dimensions and accuracy conform to TMT standards.

# GENERAL TOOLHOLDER SIDE CUTTER ARBOR

**BIG**  
CAPTO  
SHANK



● Model Description

**C6** - **SCA** **25.4** - **75**

- L dimension
- Spigot diameter
- SIDE CUTTER ARBOR A
- Shank No.

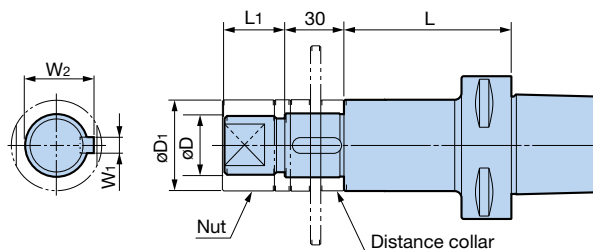

## C6/C8

Model	øD (h6)	øD <sub>1</sub>	L	L <sub>1</sub>	W <sub>1</sub>	W <sub>2</sub>	Weight (kg)
<b>C6-SCA25.4 - 75</b>	25.4	40	75	25	6.35	27.78	2.0
<b>-120</b>			120				2.4
<b>-SCA31.75- 75</b>	31.75	46	75	30	7.92	34.92	2.4
<b>C8-SCA25.4 - 90</b>	25.4	40	90	25	6.35	27.78	3.3
<b>-SCA31.75- 90</b>	31.75	46	90	30	7.92	34.92	3.7

1. Nut is included.

2. One collar each of thickness 5, 8, 10 and 12 is included.

3. The model, dimensions and accuracy conform to TMT standards.

Center through

**BIG CAPTO**  
Extension

- Extends length of basic holders.

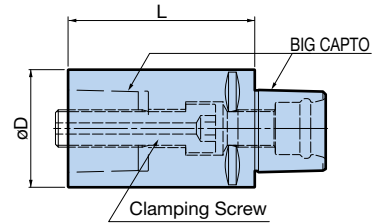
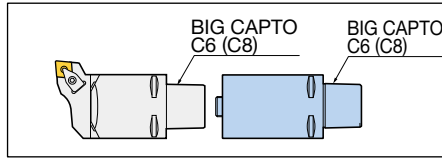

Model	BIG CAPTO	øD	L	Clamping Screw			Weight (kg)
				Thread	Hex	Torque	
<b>C6-C6-100</b>	C6	63	100	M20xP2	14mm	170N·m	1.2
<b>C8-C8-100</b>	C8	80					1.7

1. Clamping screws are included, but hex wrench is not.
2. When used for turning tools, connect by aligning with the phase of the hole on the taper shank.

Center through

**BIG CAPTO**  
Reduction

- Reduces body diameter to avoid interference.

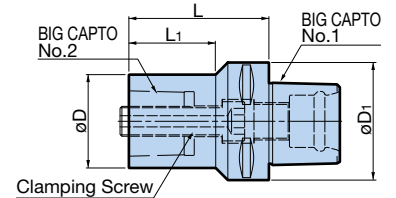
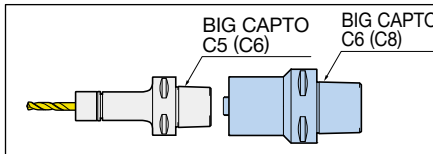

Model	BIG CAPTO No.1	BIG CAPTO No.2	øD	øD <sub>1</sub>	L	L <sub>1</sub>	Clamping Screw			Weight (kg)
							Thread	Hex	Torque	
<b>C6-C5-75</b>	C6	C5	50	63	75	46	M16xP1.5	10mm	95N·m	0.5
<b>C8-C6-85</b>	C8	C6	63	80	85	50	M20xP2	14mm	170N·m	0.8

1. Clamping screw is included, but hex wrench is not.
2. When connected with a turning tool, align the holes on the polygon taper.

OTHER TOOLS

Center through

**BIG-PLUS BASIC HOLDER**

- The ideal basic holder when using BIG CAPTO as a modular system with machining centers. Stable accuracy and rigidity are obtained with the Dual Contact BIG-PLUS spindle system.

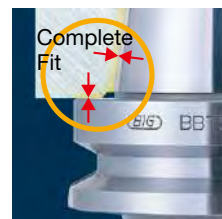
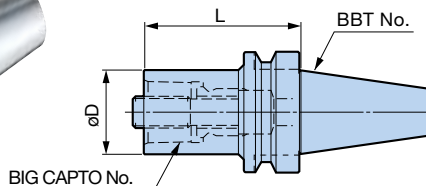

- Increased rigidity with extended reference diameter.
- Extended tool life
- Improved surface finish and dimensional accuracy.
- Elimination of Z-axis movement at high speeds.



**BIG-PLUS Basic Holder**

**BIG CAPTO Holders**

Can be used on both BIG-PLUS spindles and conventional **BT spindles**.

Model	BIG CAPTO No.	øD	L	Clamp Screw			Weight (kg)
				Thread	Hex	Torque	
<b>BBT40-C3-30</b>	C3	32	30	M12xP1.5	8mm	40N·m	1.0
<b>-C4-40</b>	C4	40	40	M14xP1.5		50N·m	1.1
<b>-C5-50</b>	C5	50	50	M16xP1.5	10mm	95N·m	1.2
<b>-C6-75</b>	C6	63	75	M20xP2		170N·m	1.7
<b>BBT50-C3-40</b>	C3	32	40	M12xP1.5	8mm	40N·m	3.6
<b>-C4-40</b>	C4	40		M14xP1.5		50N·m	
<b>-C5-40</b>	C5	50	50	M16xP1.5	10mm	95N·m	3.5
<b>-C6-50</b>	C6	63		M20xP2		14mm	
<b>-C8-70</b>	C8	80	70	M20xP2	14mm	170N·m	4.0

1. Center through coolant supply is available.