

# N/C LATHE TOOLING

---

- COLLET CHUCK ..... F1
- CENTER ADJUSTABLE HOLDER FOR LATHE ... F4
- HYDRAULIC CHUCK..... F7
- FOR DRIVEN TOOL ..... F10
- TAPPER ..... F13

The ultra-slim nut enables installation from the back of the tool post even in small lathes with limited space.

Center through

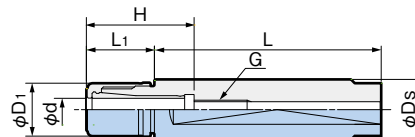

## ● Model Description

SL15.875 - MEGA 6 S - 60

- L dimension
- MICRO CHUCK
- Maximum clamping diameter
- MEGA CHUCK System
- Side lock shank diameter

Model	$\varnothing d$	$\varnothing D_s$	$\varnothing D_1$	L	L <sub>1</sub>	H	G	Weight (kg)				
SL15.875-MEGA6S- 60	0.45 - 6.05	15.875	14	60	18	28.5	M7 P0.75	0.09				
SL16 -MEGA6S- 60		16		0.11								
SL19.05 -MEGA6S- 40		40		0.10								
- 80		80		0.16								
-MEGA8S- 40	2.95 - 8.05	19.05	18	40	19	31	M9 P0.75	0.10				
- 80				80				0.16				
SL20 -MEGA6S- 40	0.45 - 6.05	20	14	40	18	28.5	M7 P0.75	0.10				
- 80				80				0.17				
-MEGA8S- 40	2.95 - 8.05			18				40	19	31	M9 P0.75	0.11
- 80								80				0.18

1. Nut is included. Collet and wrench must be ordered separately.

2. Weight includes the nut but not the collet.

F

COLLET CHUCK

Standard Accessory	Optional Accessories				
<b>MEGA NUT</b>  For Spares	<b>Mega Wrench</b>  	<b>Micro Collet</b>  	<b>Mega Micro Seal Nut (for 6S and 8S)</b> <b>Mega Micro Coolant Nut (for 6S)</b>  	<b>Collet Case</b>  	<b>Adjusting Screw</b>  

Flange acts as a stopper and reduces time for preset off the machine significantly.  
Designed to be directly mounted into the oil hole drill holder on the turret.

Center through

**[With Stopper]**

## ● Model Description

**SLS25** - **NBS** **13** - **30**

- L1 dimension
- Maximum clamping diameter
- NEW BABY CHUCK System
- Side lock shank diameter

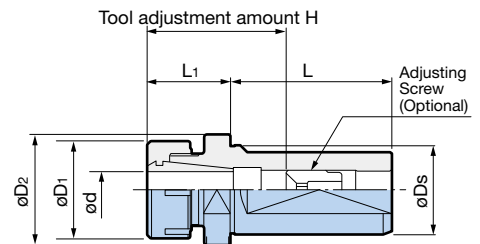

Model	$\varnothing d$	$\varnothing D_s$	$\varnothing D_1$	$\varnothing D_2$	L	L <sub>1</sub>	H
<b>SLS25-NBS13- 30</b>	2.5 - 13	25	35	32	54	30	41 - 60
- 60						60	
<b>SLS32-NBS13- 30</b>	2.5 - 13	32	35	39.5	58	30	41 - 60
- 60						60	
-100						100	
<b>-NBS20- 30</b>	2.5 - 20	40	46	45.5	68	30	48 - 65
- 60						60	
-100						100	
<b>SLS40-NBS13- 30</b>	2.5 - 13	40	35	49.5	68	30	41 - 60
- 60						60	
-100						100	
<b>-NBS20- 30</b>	2.5 - 20	40	46	49.5	68	30	48 - 65
- 60						60	
-100						100	

1. Nut is included. Adjusting Screw, collet and wrench must be ordered separately.
2. Center through coolant supply is available.
3. Tool adjustment amount "H" indicates the adjustment length with an Adjusting Screw.

Standard Accessory	Optional Accessories				
<b>New Baby Nut</b>  For Spares 	<b>New Baby Wrench</b>  	<b>Collet</b>  	<b>BABY PERFECT SEAL</b>  	<b>Adjusting Screw</b>  	<b>Tap Adjusting Screw</b>  

When ordering a **BABY PERFECT SEAL**, the "Nut-Less Body" without the standard nut attached is also available.

● **Example** Attach **/NL (Nut less)** to the end of the holder model number and order the NBC Collet/BABY PERFECT SEAL separately.



+



+

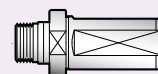

BABY PERFECT SEAL Model  
**BPS13-03035**

NBC Collet  
**NBC13-3AA**

NEW BABY CHUCK Model + NL  
**SLS25-NBS13-30/NL**  
(NL at the end of the model number means nut not attached)

Ideal as a basic holder for drills, taps and reamers on lathes!

Center through

[Standard]



## ● Model Description

<b>SL16</b>	-	<b>NBS</b>	<b>6</b>	-	<b>40</b>

● L dimension  
 ● Maximum clamping diameter  
 ● NEW BABY CHUCK System  
 ● Side lock shank diameter

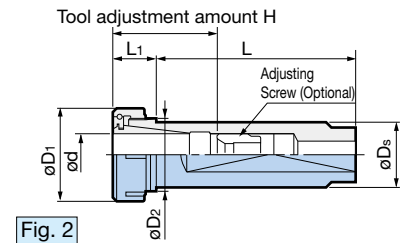
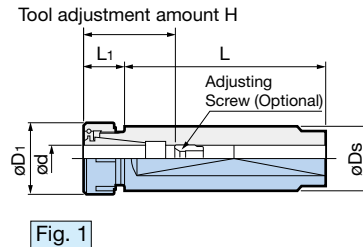

Model	Fig.	$\varnothing d$	$\varnothing D_s$	$\varnothing D_1$	$\varnothing D_2$	L	L <sub>1</sub>	H		
<b>SL16 -NBS 6- 40</b>	1	0.25 - 6	16	20	-	40	15	20 - 40		
80										
-NBS 8- 40		0.5 - 8		25		16.5	23 - 42			
				80						
-NBS10- 40	2	1.5 -10	20	30	21	40	37	35 - 45		
						80				
<b>SL20 -NBS 6- 40</b>	1	0.25- 6		20		20	-	40	15	20 - 40
								80		
-NBS 8- 40		0.5 - 8	25		16.5	23 - 42				
			80							
-NBS10- 40	2	1.5 -10	22	30	26	40	18	35 - 45		
						80				
-NBS13- 40	2	2.5 -13		25		35	26	40	21.5	41 - 60
								80		
<b>SL22 -NBS 6- 40</b>	1	0.25- 6	22		20	-		40	15	20 - 40
								80		
-NBS 8- 40		0.5 - 8		25	16.5		23 - 42			
				80						
-NBS10- 40	2	1.5 -10	25.4	30	32	40	18	35 - 45		
						80				
-NBS13- 40	2	2.5 -13		32		35	36	40	21.5	41 - 60
								80		
-NBS13- 40	1	0.25- 6	25.4		20	-		80	15	20 - 40
								120		
-NBS 8- 80		0.5 - 8		25	16.5		23 - 42			
				120						
-NBS10- 80	2	1.5 -10	32	30	36	80	18	35 - 45		
						120				
-NBS13- 80	2	2.5 -13		32		35	36	80	21.5	41 - 60
								120		
-NBS16- 80	2	2.5 -16	32		42	36		80	48	45 - 65
								120		
<b>SL25.4-NBS 6- 80</b>	1	0.25- 6		25.4	20		-	80	15	20 - 40
								120		
-NBS 8- 80		0.5 - 8	25		16.5	23 - 42				
			120							
-NBS10- 80	2	1.5 -10	32	30	36	80	18	35 - 45		
						120				
-NBS13- 80	2	2.5 -13		32		35	36	80	21.5	41 - 50
								120		
-NBS16- 80	2	2.5 -16	32		42	36		80	48	45 - 65
								120		
<b>SL32 -NBS13-100</b>	1	2.5 -13		32	35		-	100	21.5	41 - 60
								150		
-NBS16-100		2.5 -16	42		45 - 65					
			150							
-NBS20-100	2	2.5 -20	32	46	36	100	48	48 - 65		
						150				

1. Nut is included. Adjusting screw, collet and wrench must be ordered separately. 2. Center through coolant supply is available. 3. Tool adjustment amount "H" indicates the adjustment length with an Adjusting Screw.



Easy and reliable centering adjustment for turret lathe sleeve holder.

**Polar coordinate system realizing intuitive adjustment**

The rotation center of the workpiece and the center of the turret pot may be misaligned not only in the center height direction, but also in the X-axis direction.

In order to easily correct the deviation of both directions at the same time, a polar coordinate system combining rotary and linear movement is used. Single 2-way adjusting bolt completes adjustment of center height both up and down.

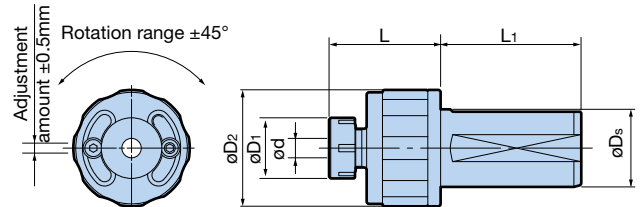

Model	$\varnothing d$	$\varnothing D_s$	$\varnothing D_1$	$\varnothing D_2$	L	L <sub>1</sub>	Weight (kg)
<b>SLS32-NBS 8CH-45</b>	0.5 - 8	32	25	48	46	58	1.6
<b>SLS40-NBS20CH-60</b>	2.5 - 20	40	46	74	60	68	2.5

- 1. Nut is included. Collet and wrench must be ordered separately.
- 2. Center through coolant supply is available.

- 3. Adjusting Screw cannot be used.

Standard Accessory	Optional Accessories		
<p>New Baby Nut</p> <p>For Spares </p>	<p>Wrench</p> <p></p>	<p>Collet</p> <p></p>	<p>BABY PERFECT SEAL</p> <p></p>

Popular 8° (single angle) taper ER collet.

Achieves stable machining with highly accurate chucking repeatability.

Center through

● Flat is provided on the shank to be mounted in the tool post of the NC lathe directly.

[With Stopper]



● Model Description

**SLS25** - **MEGA ER** **20** - **45** / **NL**

- Side lock shank diameter
- MEGA ER GRIP
- L1 dimension
- Nut-less

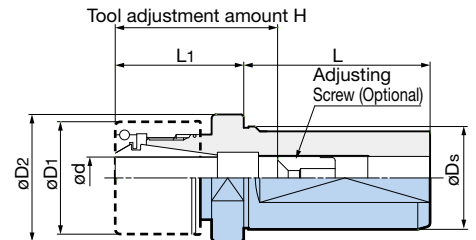

Model	$\varnothing d$	$\varnothing D_s$	$\varnothing D_1$	$\varnothing D_2$	L	L <sub>1</sub>	H	Adjusting Screw
<b>SLS25-MEGA ER20-45/NL</b>	2.75 - 13	25	35	32	54	45	42 - 62	NBA13B
<b>-75/NL</b>						75		
<b>SLS32-MEGA ER20-45/NL</b>	2.75 - 13	32	35	39.5	58	45	42 - 62	NBA13B
<b>-75/NL</b>						75		
<b>-MEGA ER32-45/NL</b>	2.75 - 20		50	50		45	47 - 68	NBA20B
<b>-75/NL</b>			75	50 - 68				
<b>SLS40-MEGA ER20-45/NL</b>	2.75 - 13	40	35	49.5	68	45	42 - 62	NBA13B
<b>-75/NL</b>						75		
<b>-MEGA ER32-45/NL</b>	2.75 - 20		50	50		45	50 - 68	NBA20B
<b>-75/NL</b>			75					

1. Collet, nut, Adjusting Screw and wrench must be ordered separately.
2. Center through coolant supply is available.
3. Tool adjustment amount "H" indicates the adjustment length with an Adjusting Screw.

#### Optional Accessories

MEGA ER NUT	MEGA ER SOLID NUT	ER Collet	ER PERFECT SEAL	Mega Wrench	ER NUT	New Baby Wrench	Adjusting Screw
							
							

Collet and nut must be ordered separately.

#### ● Example

MEGA ER PERFECT SEAL Model  
**MERPS20-030035**



MEGA ER NUT Model  
**MERN20**



MEGA ER SOLID NUT Model  
**MER20SN**



ER NUT Model  
**ERN20**



+



+

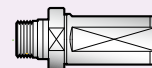

MEGA ER Collet  
**ERC20-3AA**

MEGA ER GRIP  
**SLS25-MEGA ER20-45/NL**

Clamping diameter:  $\varnothing 1.9 - \varnothing 16$ **[Standard]**

## ● Model Description

**SL16** - **MEGA ER 11** - **40** / **NL**

- Side lock shank diameter
- MEGA ER GRIP
- L dimension
- Nut less

Center through

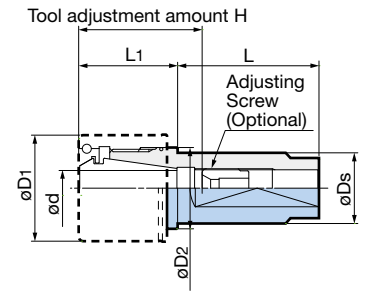

Model	$\varnothing d$	$\varnothing D_s$	$\varnothing D_1$	$\varnothing D_2$	L	L <sub>1</sub>	H	Adjusting Screw
<b>SL16-MEGA ER11- 40/NL</b>	2.75 - 6	16	19	—	40	19	23 - 40	NBA 6B
<b>- 80/NL</b>					80			
<b>SL20-MEGA ER11- 40/NL</b>	2.75 - 6	20	19	—	40	19	23 - 40	NBA 6B
<b>- 80/NL</b>					80			
<b>-MEGA ER16- 40/NL</b>	1.9 - 10		30	23	40	28	35 - 47	NBA10B
<b>- 80/NL</b>			80					
<b>SL25-MEGA ER11- 60/NL</b>	2.75 - 6	25	19	—	60	19	23 - 40	NBA 6B
<b>-100/NL</b>					100			
<b>-MEGA ER16- 60/NL</b>	1.9 - 10		30	—	60	28	35 - 47	NBA10B
<b>-100/NL</b>			100					
<b>-MEGA ER20- 60/NL</b>	2.75 - 13		35	27	60	30	42 - 62	NBA13B
<b>-100/NL</b>			100					
<b>-MEGA ER25- 60/NL</b>	2.75 - 16		42	33.5	60	48	44 - 67	NBA16B
<b>-100/NL</b>			100					
<b>SL19.05-MEGA ER11- 40/NL</b>	2.75 - 6	19.05	19	—	40	19	23 - 40	NBA 6B
<b>- 80/NL</b>					80			
<b>-MEGA ER16- 40/NL</b>	1.9 - 10		30	23	40	28	35 - 47	NBA10B
<b>- 80/NL</b>			80					

1. Collet, nut, Adjusting Screw and wrench must be ordered separately.

4. For MEGA ER11 models, only the ER NUT (hook wrench type) is available.

2. Center through coolant supply is available.

3. Tool adjustment amount "H" indicates the adjustment length with an Adjusting Screw.

**Optional Accessories**

MEGA ER NUT	MEGA ER SOLID NUT	ER Collet	ER PERFECT SEAL	Mega Wrench	ER NUT	New Baby Wrench	Adjusting Screw
							
							

## [Front-side Clamping Type]

- Most popular design available for various tool posts.
- Rc(PT)1/8 piping thread preparation for coolant through tool.
- Adjusting Screw can be used with some models.

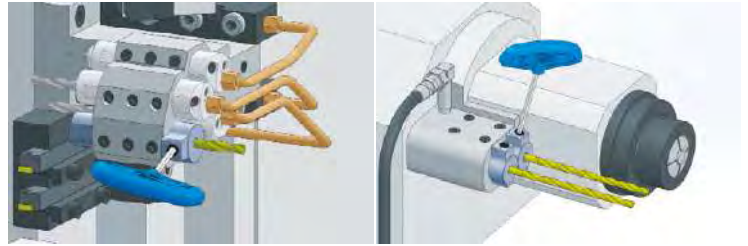

### ● Model Description

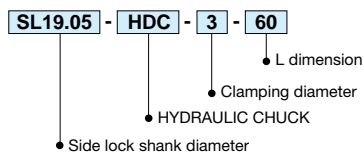

Tool adjustment amount

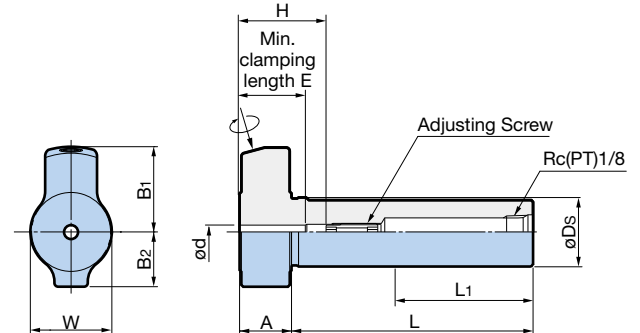

Model	Clamping diameter $\varnothing$	$\varnothing D_s$	L	L <sub>1</sub>	A	B <sub>1</sub>	B <sub>2</sub>	W	H	E	Adjusting Screw (Optional)	Weight (kg)
<b>SL19.05-HDC 3-60</b> ※	3	19.05	60	20	15	24.5	15.8	22	20 - 32	16	HDA4-05015W	0.18
<b>-HDC3.175-60</b> ※	3.175											0.18
<b>-HDC 4-60</b>	4											0.18
<b>-HDC 6-60</b>	6											0.18
<b>-HDC 8-60</b> ▲	8											0.17
<b>SL20 -HDC 3-70</b> ※	3	20	70	30	15	24.5	15.8	23	20 - 32	16	HDA4-05015W	0.22
<b>-HDC 4-70</b>	4											0.22
<b>-HDC 6-70</b>	6											0.22
<b>-HDC 8-70</b> ▲	8											0.21
<b>SL22 -HDC 3-70</b> ※	3	22	70	30	15	24.5	15.8	25	20 - 32	16	HDA4-05015W	0.26
<b>-HDC 4-70</b>	4											0.26
<b>-HDC 6-70</b>	6											0.26
<b>-HDC 8-70</b> ▲	8											0.25
<b>-HDC10-70</b> ▲	10					0.24						
<b>SL25 -HDC 3-65</b> ※	3	25	65	25	15	23	14	28	20 - 32	16	HDA4-05015W	0.31
<b>-HDC 4-65</b>	4					0.31						
<b>-HDC 6-65</b>	6					0.31						
<b>-HDC 8-65</b> ▲	8					0.31						
<b>-HDC10-65</b> ▲	10					0.29						
<b>-HDC12-65</b> ▲	12					0.28						
<b>SL25.4 -HDC 3-80</b> ※	3	25.4	80	40	15	23	14	28	20 - 32	16	HDA4-05015W	0.37
<b>-HDC 4-80</b>	4					0.37						
<b>-HDC 6-80</b>	6					0.37						
<b>-HDC 8-80</b> ▲	8					0.37						
<b>-HDC10-80</b> ▲	10					0.35						
<b>-HDC12-80</b> ▲	12					0.33						

- L<sub>1</sub> is the longest possible cutoff position.
- Tool adjustment amount "H" indicates the adjustment length with an Adjusting Screw.  
Models marked with ▲ cannot be used with Adjusting Screw. The "H" dimension is the max. insertion depth.
- Adjusting screw can be adjusted from the shank side as well.  
For HDC8/10/12, the adjusting screw cannot be used.
- When using coolant with models marked with ※, some coolant may leak from the inner diameter slits.

- It is recommended to use a Grip Bar to periodically confirm the gripping force of the Hydraulic Chuck. G30

### Caution

- Use only cutting tools that have a shank diameter within h6.  
Do not use with cutting tools made with a flat on the shank (ie: Weldon type shank).
- Do not clamp without a tool.
- Always insert the cutting tool into the holder beyond min. clamping length E.



**[Back-side Clamping Type PAT.F]** Registered Design

- Tighten from the opposite side of the cutting tool.  
Ideal for use on the Tool-Post 1.
- Rc(PT)1/8 piping thread preparation for coolant through tool.
- Slim design avoids interference with adjacent tools.



Extensive product lineup!

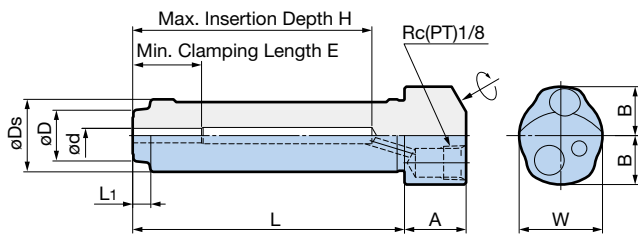
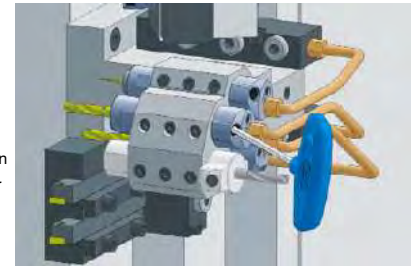
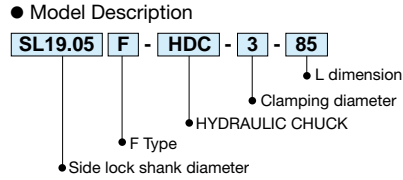

Fig. 1

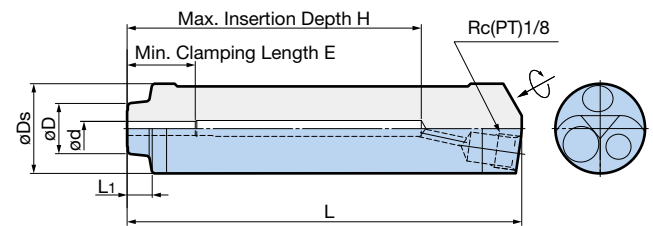

Fig. 2

Model	Fig.	Clamping diameter $\phi d$	$\phi D$	$\phi D_s$	L	L1	A	B	W	H	E	Weight (kg)
<b>SL19.05F-HDC 3- 85</b> ※	1	3	14	19.05	85	5	17	13.5	22	76	16	0.22
<b>-HDC3.175- 85</b> ※		3.175									19	
<b>-HDC 4- 85</b>		4									25	
<b>-HDC 6- 80</b>		6									31	
<b>-HDC 8- 80</b>		8									31	
<b>SL20F -HDC 3- 75</b> ※	1	3	14	20	75	5	17	13.5	23	66	16	0.22
<b>-HDC 4- 75</b>		4								19		
<b>-HDC 6- 70</b>		6								25		
<b>-HDC 8- 70</b>		8								31		
<b>SL22F -HDC 3- 75</b> ※	1	3	14	22	75	5	17	13.5	25	66	16	0.26
<b>-HDC 4- 75</b>		4								19		
<b>-HDC 6- 70</b>		6								25		
<b>-HDC 8- 70</b>		8								31		
<b>-HDC10- 70</b>		10								33		
<b>SL25F -HDC 3-110</b> ※ <b>NEW</b>	2	3	14	25	110	7	-	-	-	82	16	0.37
<b>-HDC 4-110</b> <b>NEW</b>		4								19		
<b>-HDC 6-105</b> <b>NEW</b>		6								25		
<b>-HDC 8-100</b> <b>NEW</b>		8								31		
<b>-HDC10- 95</b> <b>NEW</b>		10								33		
<b>-HDC12- 90</b> <b>NEW</b>		12								36		
<b>SL25.4F -HDC 3-105</b> ※ <b>NEW</b>	2	3	14	25.4	105	7	-	-	-	77	16	0.36
<b>-HDC 4-105</b> <b>NEW</b>		4								19		
<b>-HDC 6-100</b> <b>NEW</b>		6								25		
<b>-HDC 8- 95</b> <b>NEW</b>		8								31		
<b>-HDC10- 90</b> <b>NEW</b>		10								33		
<b>-HDC12- 85</b> <b>NEW</b>		12								36		

- When using coolant with models marked with ※, some coolant may leak from the inner diameter slits.
- Adjusting Screw cannot be used.

● It is recommended to use a Grip Bar to periodically confirm the gripping force of the Hydraulic Chuck. G30

**Caution**

- Use only cutting tools that have a shank diameter within h6.  
Do not use with cutting tools made with a flat on the shank. (ie: Weldon type shank).
- Do not clamp without a tool.
- Always insert the cutting tool into the holder beyond min. clamping length E.

**[Rear-post Type]** Registered Design

- Tool change with a single wrench avoiding adjacent tools and coolant pipes.
- Easy tool setup even at the lower tool post.
- M6 piping thread preparation for coolant through tool available in upper tool post.

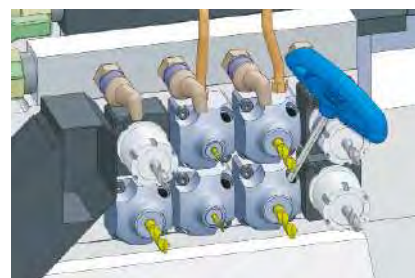

● Model Description

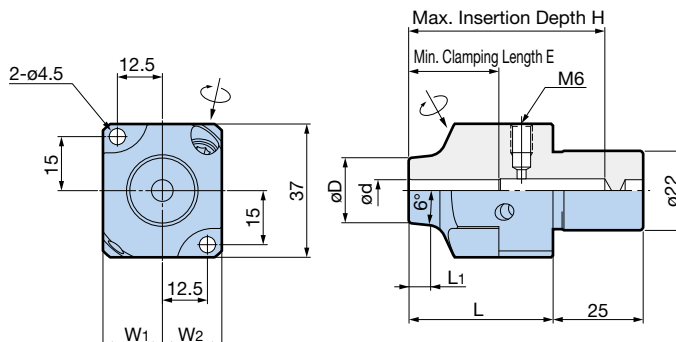
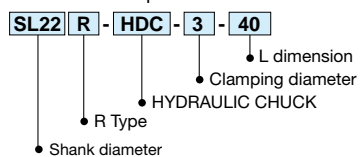

Model	Clamping diameter $\varnothing d$	$\varnothing D$	L	L <sub>1</sub>	W <sub>1</sub>	W <sub>2</sub>	H	E	Weight (kg)
<b>SL22R-HDC 3-40</b> ※	3	14	40	7	16.5	16.5	35	16	0.34
<b>-HDC 4-40</b>	4			9			42	19	0.33
<b>-HDC 6-40</b>	6	5		55			25	0.36	
<b>-HDC 8-40</b>	8	6		54	31	0.36			
<b>-HDC10-40</b>	10	22			17.5	33	0.35		

1. When using coolant with models marked with ※, some coolant may leak from the inner diameter slits.
2. Adjusting Screw cannot be used.

- It is recommended to use a Grip Bar to periodically confirm the gripping force of the Hydraulic Chuck. **G30**
- Confirm the mounting dimensions of the machine in advance.

**Caution**

- Use only cutting tools that have a shank diameter within h6.
- Do not use with cutting tools made with a flat on the shank. (ie: Weldon type shank).
- Do not clamp without a tool.
- Always insert the cutting tool into the holder beyond min. clamping length E.

HYDRAULIC CHUCK

**EWN04-7/EWN04-15 BORING HEAD**

- Micro-boring head with outer diameter of  $\phi 18.5\text{mm}$  (EWN04-7).
- $0.01\text{mm/scale}/\phi 2\mu\text{m}$  ultra-precision vernier.

[ Cylindrical Shank Type ] **NEW** Diameter:  $\phi 1 - \phi 15$



● Model Description  
**EWN 04 - 7 ST10**  
 ● Cylindrical shank No.  
 ● Diameter  
 ● FINISH BORING HEAD

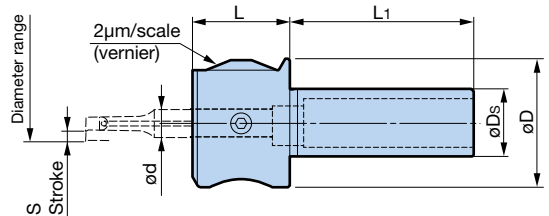

Model	Diameter range	$\phi D$	$\phi D_s$	$\phi d$	L	L <sub>1</sub>	S	Max. spindle speed	Weight (kg)
<b>EWN04- 7ST10</b>	1.0 - 7	18.5	10	4	14	25	-0.1 - +1.05	30,000	0.04
<b>EWN04-15ST16</b>	1.0 - 15	30	16	7	22	34	-0.2 - +2.0	20,000	0.13

1. Cylindrical tool must be ordered separately.

Tool systems **A62**

Spare Parts **A103**

**EWN BORING HEAD** (cylindrical tool type for finishing)

- Ultra precision head with an adjustable amount of microns.
- The enhanced carbide tool series immediately supports small & deep-hole boring.
- Precision diameter adjustment function for the vernier with  $0.01\text{mm}/\phi +2\mu\text{m}$  scale.

For turning center

**[ER Chuck Type]** Diameter:  $\phi 1 - \phi 32$

To be mounted on the ER collet chuck live tooling for lathe in place of the clamping nut.

**Center through**



● Model Description  
**EWN 2 - 22 ER25**  
 ● ER No.  
 ● Max. diameter  
 ● FINISH BORING HEAD

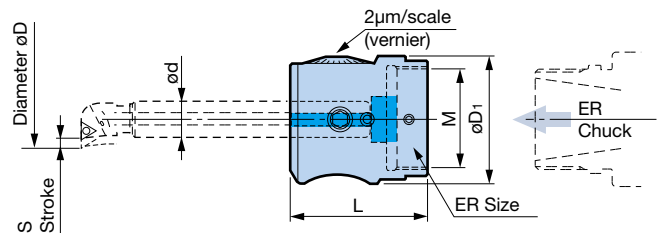

Diameter $\phi D$	Model	ER size	$\phi d$	$\phi D_1$	L	S	M	Weight (kg)
1 - 22	<b>EWN2-22ER25</b>	ER25	10	39	40.5	2.0	M32x1.5	0.25
1 - 32	<b>EWN2-32ER32</b>	ER32	12	50	51	3.5	M40x1.5	0.5

1. EWN BORING HEAD does not come with cylindrical tool.
2. Center through coolant supply is available.
3. Inserts must be ordered separately.

Tool systems **A67**

Spare Parts **A103**

# SMART DAMPER BORING BAR

The heaviest damper in the Smart Damper series instantly absorbs chatter in both rough and finish operations.



With coolant hole

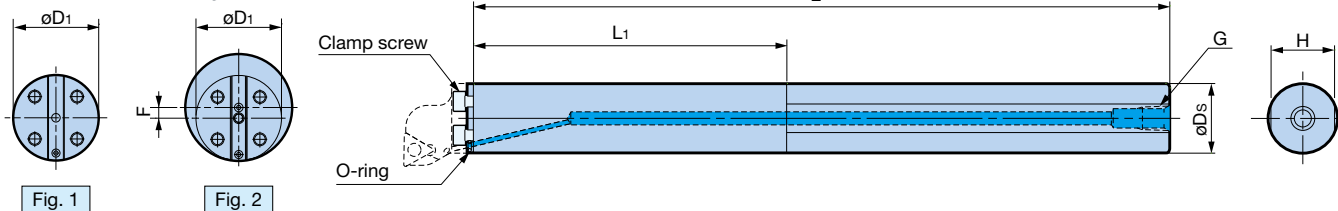

Fig. 1

Fig. 2

Model	Fig.	Cartridge Model	øDs	øD1	Min. Diameter	L	L1	H	G	F	Spare clamping screw (1)	Spare O-ring set (2 pcs)	Weight (kg)
ST32-SDB40DP-320	1	B32-...	32	32	40	320	144	30	Rc(PT)1/4	—	C0510(M5×10L)	SDB20 OR-2P	2.3
ST40-SDB50DP-410	1	B40-...	40	40	50	410	170	37	Rc(PT)3/8	—	C0610(M6×10L)	SDB20 OR-2P	4.5
ST50-SDB60DP-520	2	B40-...	50	50	60	520	190	47	Rc(PT)3/8	5	C0610(M6×10L)	SDB20 OR-2P	8.9

1. Clamp screws (3 pcs) and O-rings (2 pcs) are included.
2. Cartridges must be ordered separately.
3. Coolant through is standard for all models.
4. Do not clamp the L1 dimension, where the damper is built-in.
5. ST50 shank tip cartridge is common with the ST40 shank.

## Cartridge

[Screw-on Type] (for positive insert)

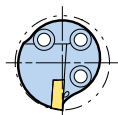

Figure shows right hand

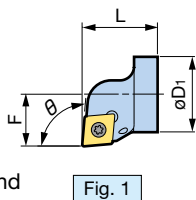

Fig. 1

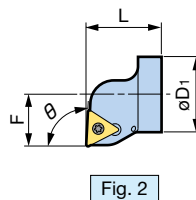

Fig. 2

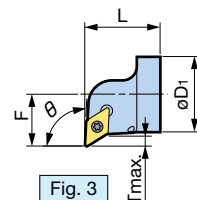

Fig. 3

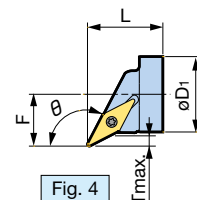

Fig. 4

Model	Fig.	Insert	Hand	øD1	F	L	Tmax.	θ	Insert Clamping Screw Set	Weight (kg)
B32-SCLCR-22032-12	1	CC1204	Right hand	32	22	32	—	95°	S5 S-20IP	0.1
-STUCR-22032-11	2	TC1102						93°	S2.5S-7IP	
-STUPR-22032-16		TP1604						4	S4 S-15IP	
-SDUCR-22032-11	3	DC11T3						1.5	S3.5S-15IP	
-SVPBR-22032-16	4	VB1604						117.5°	S3.5S-15IP	
B40-SCLCR-27032-12	1	CC1204	Right hand	40	27	32	—	95°	S5 S-20IP	0.2
-STUCR-27032-11	2	TC1102						93°	S2.5S-7IP	
-STUPR-27032-16		TP1604						4	S4 S-15IP	
-SDUCR-27032-11	3	DC11T3						3	S3.5S-15IP	
-SVPBR-27032-16	4	VB1604						117.5°	S3.5S-15IP	

1. A wrench and screw are included but inserts are not.
2. The insert clamping screw set (optional) contains 10 screws and 1 wrench.

## Insert Clamping Screw Set

Set Model	Screw	Wrench Model
S2.5S- 7IP	M2.5 × 6.5	FS- 7IP
S3.5S-15IP	M3.5 × 8	FS-15IP
S4 S-15IP	M4 × 8	FS-15IP
S5 S-20IP	M5 × 12	FS-20IP

1. Wrench is also available separately. Please order the wrench model.

# INTERNAL TURNING TOOL WITH BUILT-IN DAMPER SMART DAMPER BORING BAR

## Double Clamp Type (for negative insert)

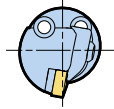

Figure shows right hand

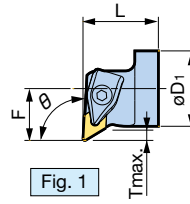

Fig. 1

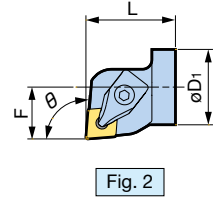
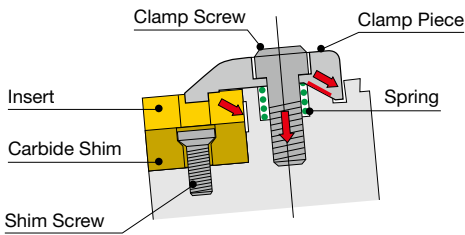

Fig. 2

Model	Fig.	Insert	Hand	øD1	F	L	Tmax.	θ	Clamp Piece	Carbide Shim	Weight (kg)
<b>B32-DDUNR-22032-11</b>	1	DN1104	Right hand	32	22	32	4	93°	CP7	DNS1104C	0.1
<b>-DCLNR-22038-12</b>	2	CN1204				38	—	95°	CP2	CNS1204C	
<b>B40-DDUNR-27032-15</b>	1	DN1506※ (DN1504)	Right hand	40	27	32	6	93°	CP2	DNS1506C (DNS1504C)	0.2
<b>-DCLNR-27038-12</b>	2	CN1204				38	—	95°	CP2	CNS1204C	

1. A carbide shim screw and wrench are included, but a clamp piece tightening wrench is not.
2. Inserts are not included.

※ A carbide shim for DN1506 (thickness: 6.35mm) is included.  
When using a DN1504 insert (thickness: 4.76mm), replace the standard carbide shim with the DNS1504C (optional).



## Clamp Piece Set

Set Model	Clamp Piece	Clamp Screw	Spring	Compatible Insert
<b>SCP2</b>	CP2	M5×20	ø8×10	CN1504, DN1506 CN1204
<b>SCP7</b>	CP7			DN1104

1. 1 pc. each of the clamp piece, clamp screw and spring are included in the set.
2. The tightening wrench is a 4mm hex wrench. T-type hex wrench is sold as Model T-4.

## Carbide Shim Set

Compatible Insert	Set Model	Carbide Shim	Shim Screw	Torx Plus Size
DN1104	<b>SDNS1104C</b>	DNS1104C	M3×7	10IP
DN1504	<b>SDNS1504C</b>	DNS1504C	M4×8	15IP
DN1506	<b>SDNS1506C</b>	DNS1506C	M4×8	15IP
CN1204	<b>SCNS1204C</b>	CNS1204C	M4×8	15IP

1. 1 pc. each of the carbide shim and screw are included in the set.
2. The tightening wrench is a Torx plus wrench.

## Torx Plus Wrench (optional)

Set Model	Torx Plus Size
<b>FS-10IP</b>	10IP
<b>FS-15IP</b>	15IP

## A double-clamping system that utilizes a "Push and Draw" mechanism to fix inserts securely

Secure insert clamping has been realized through the double-clamping system, which pushes the insert downwards while at the same time generating drawing force on the insert contact surface.

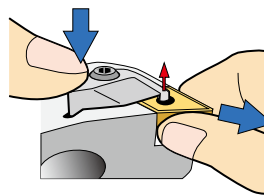

## Easy attachment and removal of inserts

Insert attachment and removal can be performed easily thanks to the built-in spring. Loosen the clamp screw one full rotation, lightly press the clamp piece with a finger, and its tip will pop up.

Improves thread quality and tap life by reducing thrust loads caused by synchronization errors up to 90%.



[Small Diameter Tap MGT3 Type PAT.]

· Cannot be used with machines without a synchronized tapping function.

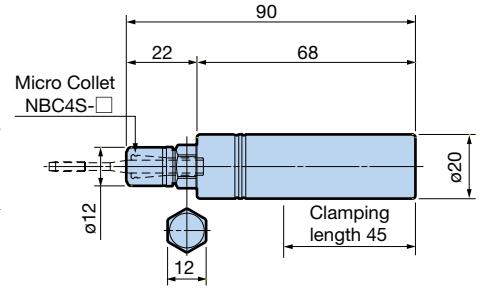
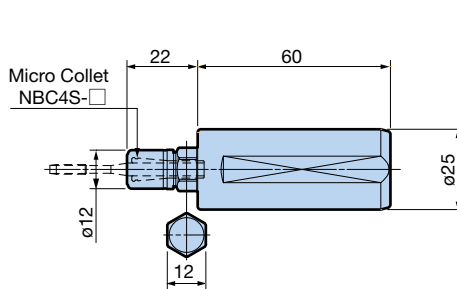

● Model Description

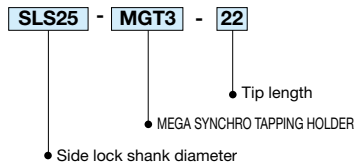

Model	<b>SLS25-MGT3-22</b>
-------	----------------------

- Nut is included (MGN4S). Collet and wrench must be ordered separately.
- When attaching or detaching the tap, use Mega Wrench and a commercially available flat wrench (12mm).

Model	<b>ST20-MGT3-90</b>
-------	---------------------

- Nut is included (MGN4S). Collet and wrench must be ordered separately.
- There is no flat on the shank part.
- When attaching or detaching the tap, use Mega Wrench and a commercially available flat wrench (12mm).



■ Micro Collet

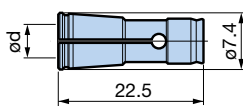

Model	Tapping range			Tap shank diameter $\phi d$
	JIS-M	JIS-U	DIN371	
<b>NBC4S - 2.5AA</b>			M1-M1.8	2.5
<b>2.8AA</b>			M2-M2.6	2.8
<b>3.0AA</b>	M1 - M2.6	No.0 - 4		3.0
<b>3.5AA</b>			M3	3.5
<b>4.0AA</b>	M3	No.5, 6		4.0

● Collet accuracy

Collet class	Runout accuracy	
	Nose	4D
AA	Within 1 $\mu m$	Within 3 $\mu m$

F  
TAPPER

# SYNCHRONIZED TAP HOLDER R

- Built-in radial float mechanism absorbs misalignment with the spindle center. Excellent for rigid tapping with NC Lathes.
- Small axial float absorbs synchronization errors occurring when changing over the rotation from forward to reverse, reducing loads to the tap.

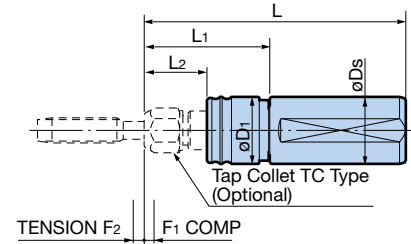

Radial float =  $\pm 0.5\text{mm}/\phi$

● Model Description

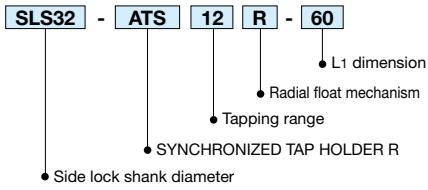

Model	Tapping range	$\phi D_s$	$\phi D_1$	L	L <sub>1</sub>	L <sub>2</sub>	F <sub>1</sub>	F <sub>2</sub>	Compatible Tap Collet
<b>SLS32-ATS12R- 60</b>	M3 - M12	32	32	125	60	30	0.5	0.5	TC12-□
<b>SLS40-ATS12R- 60</b>		40	32	125	60	25	0.5	0.5	
<b>-ATS20R- 70</b>	M8 - M20	40	44	145	70	25	0.5	0.5	TC20-□

1. Tap Collet is not included.  
TC Tap Collet must be ordered separately.

F<sub>1</sub>: Compression amount  
F<sub>2</sub>: Tension amount

● **Cannot be used with machines without a synchronized tapping function.** Tap Collets **A144**

# AUTO TAPPER SERIES

## AUTO TAPPER B M3 - M20

Automatic depth control

- Auto depth control eliminates variation in the tapping depth. Ideal for blind-hole or pipe tapping.
- Minimized projection length avoids interference on turret lathes.



● Model Description

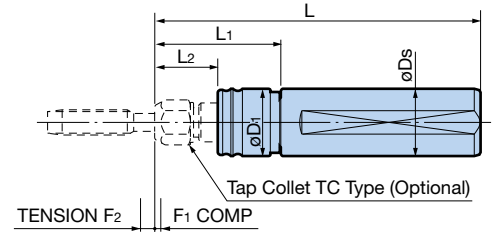
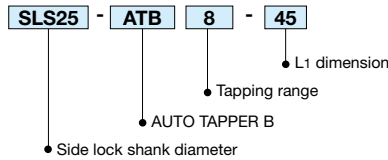

Model	Tapping range	øDs	øD1	L	L1	L2	F1	F2	Compatible Tap Collet
<b>SLS25-ATB 8-45</b>	M3 - M 8	25	25.5	130	45	17	0.5	3	TC 8-□
<b>SLS32-ATB12-60</b>	M3 - M12	32	32	155	60	30		4	TC12-□
<b>SLS40-ATB12-60</b>		40	32	155	60	25		4	TC20-□
<b>-ATB20-70</b>	M7 - M20	40	44	180	70			5	

1. Tap Collet is not included. TC Tap Collet must be ordered separately.
2. Cannot be used for left-hand thread machining.
3. F<sub>2</sub> dimension in the table is the tension amount until it reaches neutral.

F1: Compression amount  
F2: Tension amount

Tap Collets **A144**

TAPPER

## AUTO TAPPER E M3 - M24

Torque limiter

- Easy-to-use built-in torque limiter.
- Extended axial float allows stable and reliable use.



● Model Description

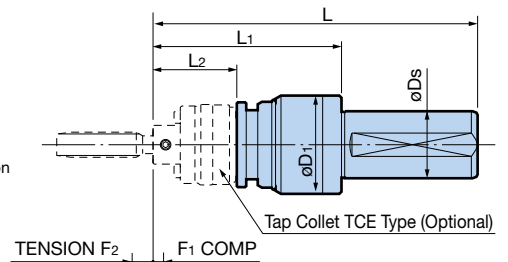
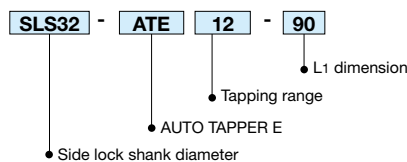

Model	Tapping range	øDs	øD1	L	L1	L2	F1	F2	Compatible Tap Collet
<b>SLS32-ATE12- 90</b>	M3 - M12	32	47	155	90	40	5	10	TCE12-□
<b>SLS40-ATE12- 90</b>		40	47	165	90	40	5	10	
<b>-ATE24-135</b>	M9 - M24	40	64	210	135	55	7	15	TCE24-□

1. Tap Collet is not included. TCE Tap Collet must be ordered separately.
2. Cannot be used for left-hand thread machining.

F1: Compression amount  
F2: Tension amount

Tap Collets **A147**